



T-Series Precision Linear Actuators

Installation and Service Manual

DW110353GB-1018 - EDITION 5

www.thomsonlinear.com

 THOMSON™
Linear Motion. Optimized.

Version History

Edition Number	Edition Date	Reason for Revision
1	2004	First edition
2	2005-02-10	Updated with new T90 versions
3	2006-05-19	Figure numbering corrected
4	2007-04-17	Lubrication instructions updated
5	2010-05-05	T60 and T130 with 50 diameter screw added, style updated

Technical changes to improve the performance of the equipment may be made without notice!

All rights reserved. No part of this work may be reproduced in any form (by printing, photocopying, microfilm or any other method) or processed, copied or distributed by electronic means without the written permission of Thomson. Printed in Sweden.

Table of Contents

1. Type designation system	4
2. Mounting instructions	5
2.1 Installation.....	5
2.2 Connection of load.....	6
2.3 Motor flange.....	6
2.4 Feet mounting kit.....	7
2.5 Trunnion mounting kits.....	7
2.6 Mounting of worm gear type BS40 / BS50.....	8
2.7 Installation of magnetic sensors.....	8
3. Service and maintenance	9
3.1 General maintenance instructions.....	9
3.2 Lubrication.....	10
4. Technical data	11
4.1 Technical data.....	11

1. Type designation system

T60, T90 and T130					
1	2	3	4	5	6
T09-B	2525	M	P	045	S1
1. Model T06-B = T60 unit T09-B = T90 unit T13-B = T130 unit			4. Type of adapter N = M16 × 1,5 outside thread (only possible for T06-B25 ** and T09-B25 **) P = M16 × 2 inside thread (only possible for T09-B25 **) Q = M20 × 1,5 outside thread (only possible for T09-B32 **) R = M20 × 1,5 inside thread (only possible for T09-B32 **) S = M27 × 2 outside thread (only possible for T13-B40 **) T = M27 × 2 inside thread (only possible for T13-B40 **) U = M33 × 2 outside thread (only possible for T13-B40 ** and T13-B5010) V = M33 × 2 inside thread (only possible for T13-B40 ** and T13-B5010) X = M30 × 2 inside thread (only possible for T13-B40 **)		
2. Ball screw diameter, lead and tolerance class 2505 = 25 mm, 05 mm, T7 (only possible for T06-B and T09-B) 2510 = 25 mm, 10 mm, T7 (only possible for T06-B and T09-B) 2525 = 25 mm, 25 mm, T7 (only possible for T06-B and T09-B) 2550 = 25 mm, 50 mm, T7 (only possible for T06-B) 3220 = 32 mm, 20 mm, T7 (only possible for T09-B) 3232 = 32 mm, 32 mm, T7 (only possible for T09-B) 4010 = 40 mm, 10 mm, T7 (only possible for T13-B) 4020 = 40 mm, 20 mm, T7 (only possible for T13-B) 4040 = 40 mm, 40 mm, T7 (only possible for T13-B) 5010 = 50 mm, 10 mm, T7 (only possible for T13-B)			5. Ordering length (L order) *** = distance in cm		
3. Engineering unit M = metric			6. Protection option¹ S1 = wash down protection		
			¹ Leave blank if no protection option required.		

Table 1: Type designation system

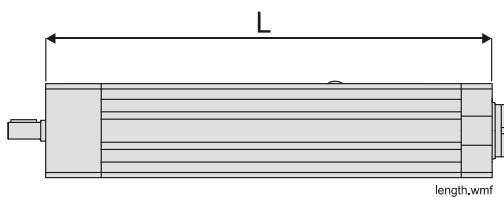
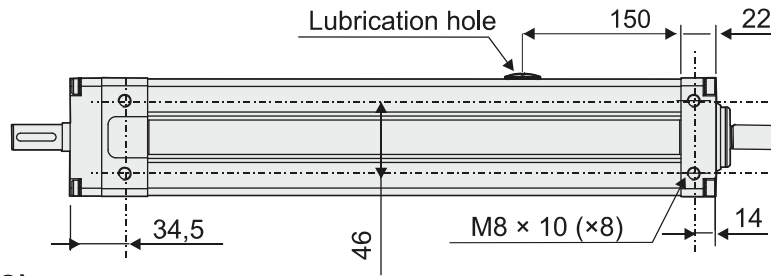
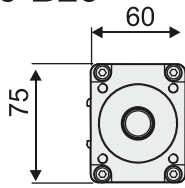

Figure 1: definition of ordering length L

2. Installation

2.1 Mounting instructions

1 T06-B25



T09-B25 (T09-B32)

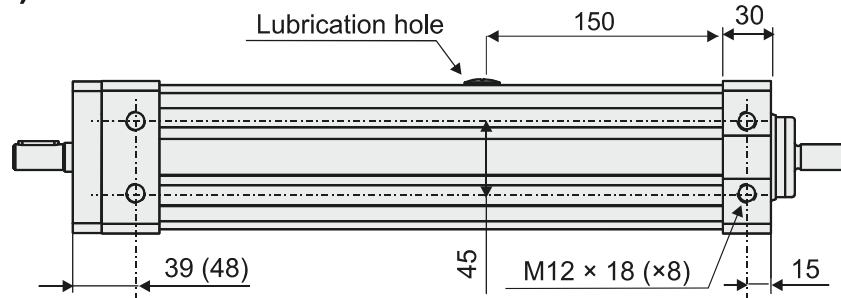
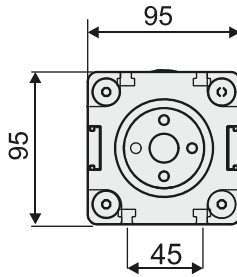

T30-B40 (T13-B50)

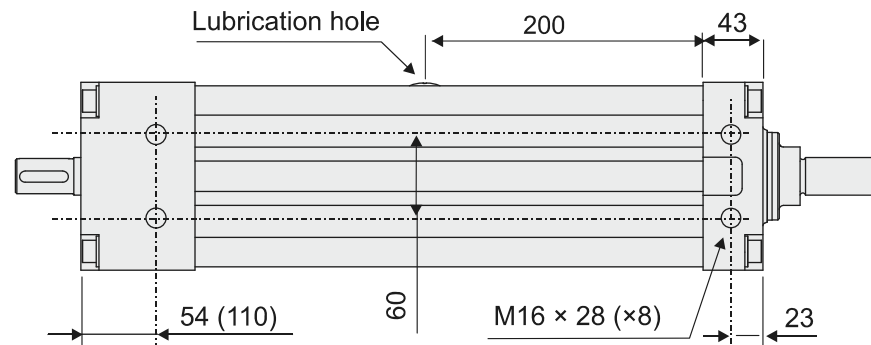
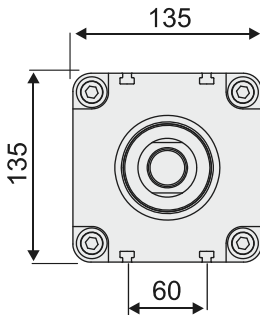

2

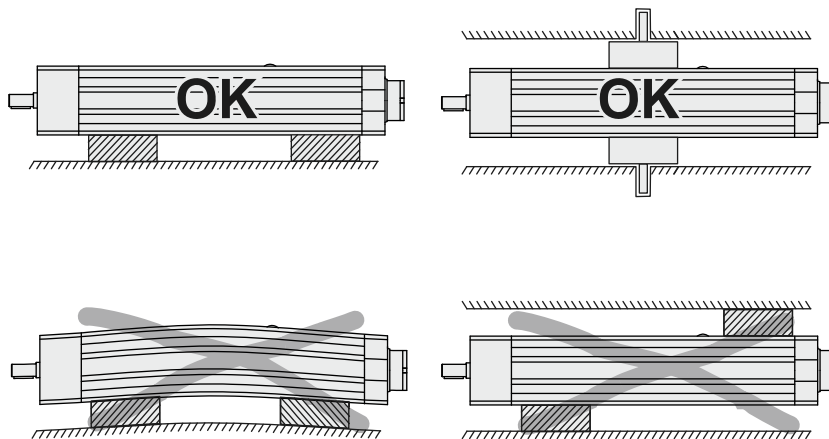

mounting_may2010.wmf

Figure 2: mounting instructions

1. The actuators have threaded holes in the front and rear housings and T-slots along the profile that can be used for mounting. Be sure to mount the actuator so that the lubrication hole is accessible.
2. Only mount the actuator to one side if not trunnion mounting is used. Do not mount the actuator so that the profile is deformed.

2.2 Connection of load

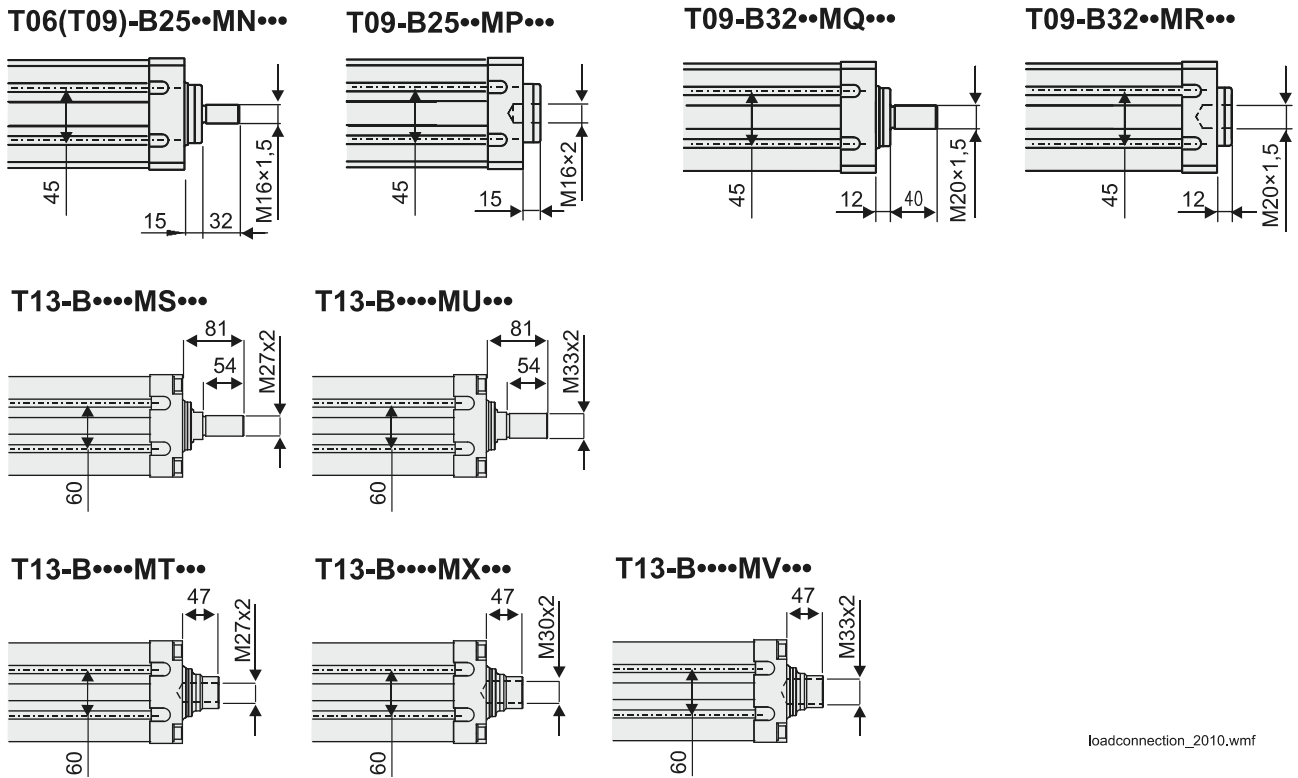

Figure 3: connection of load

2.3 Motor flange

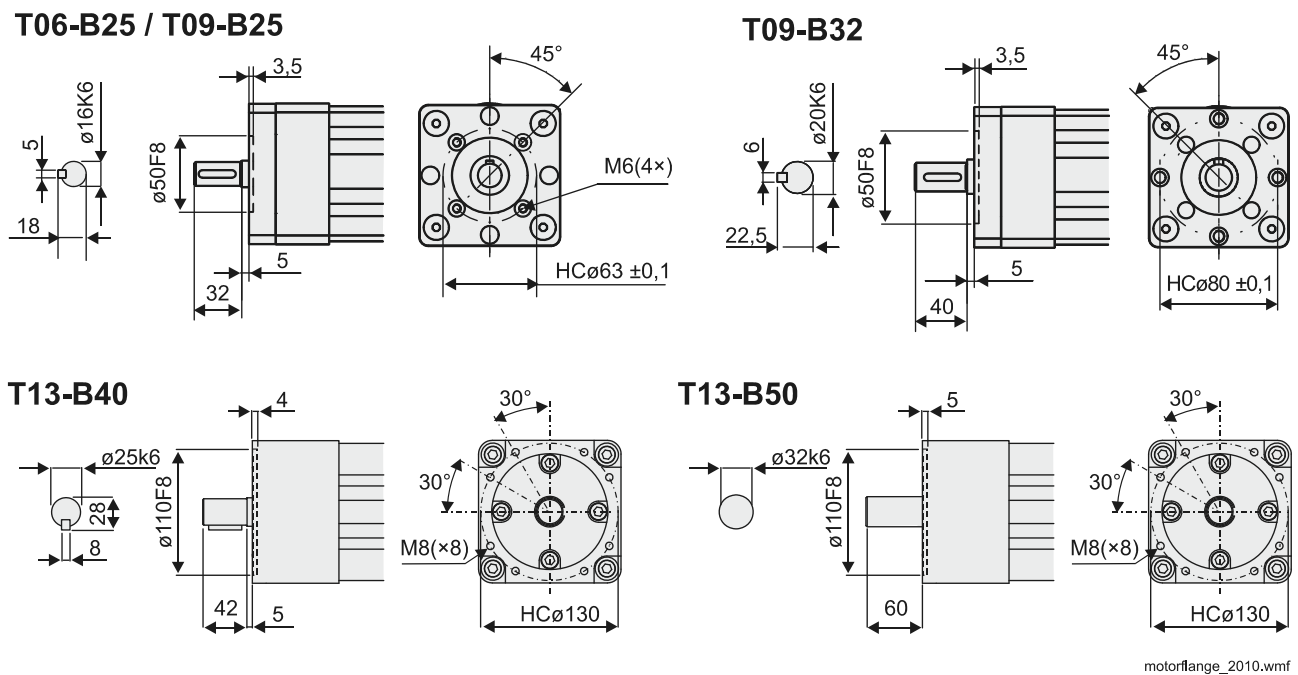

Figure 4: motor flanges

2.4 Feet mounting kit

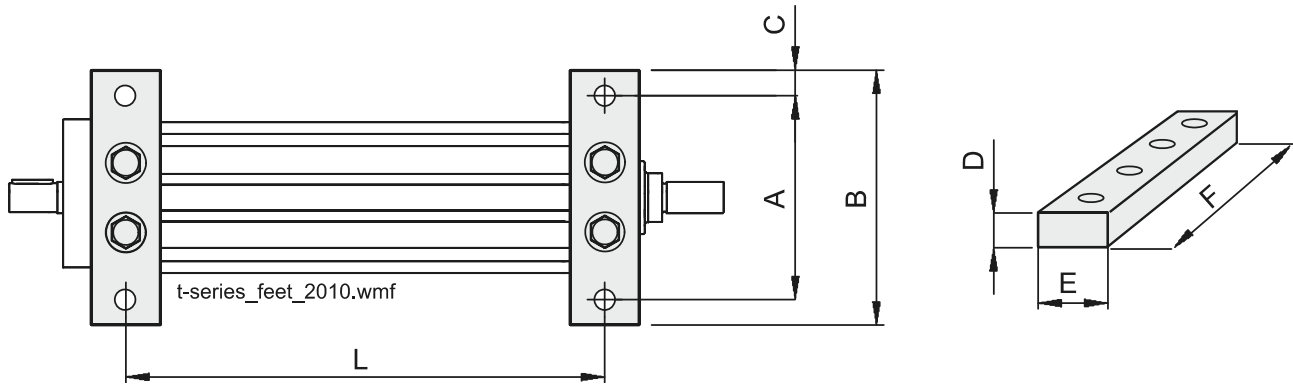

Figure 5: mounting feet

	A	B	C	D	E	F	L	Tightening torque [Nm]
T06-B25	- on request -							
T09-B25	125	155	15	20	40	155	Smax + 141	78
T09-B32	125	155	15	20	40	155	Smax + 162	78
T13-B40	176	220	22	30	60	220	Smax + 216	220

Table 2: mounting feet dimensions

2.5 Trunnion mounting kits

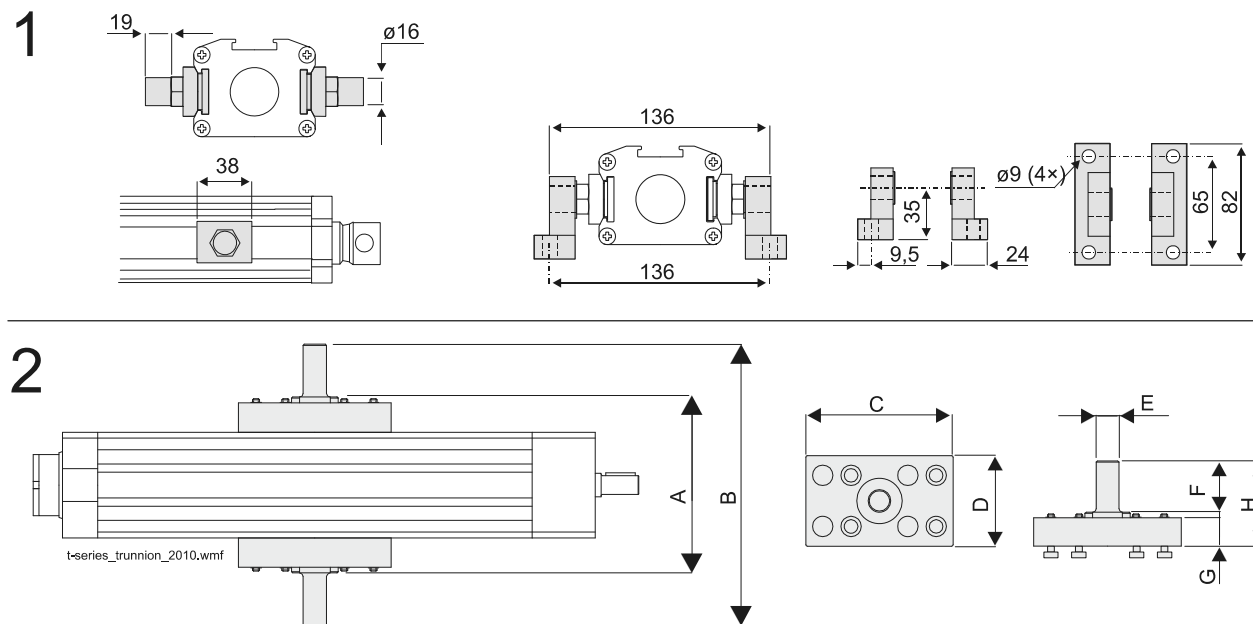

Figure 6: trunnion

	A	B	C	D	E	F	G	H	Tightening torque [Nm]
T09-B	150	240	130	80	∅20 f8	45	25	75	11
T13-B	316	210	180	110	∅35 f8	63	30	93	45

Table 3: trunnion dimensions

1. Trunnion shafts and trunnion brackets for T60.
2. Trunnion kit for T90 and T130.

Make sure to mount the bearings on the trunnion shafts as close to the unit as possible!

2.6 Mounting of worm gear type BS40 / BS50

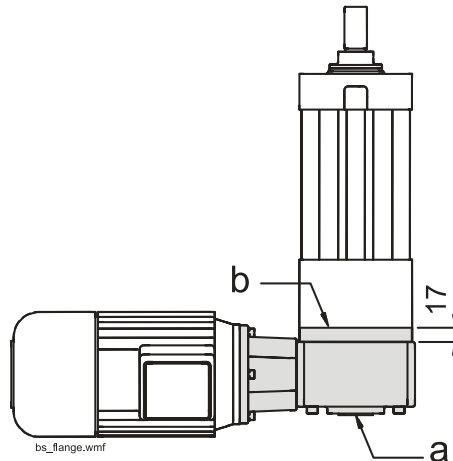

Figure 7: flange for worm gear type BS40 / BS50

To be able to mount a worm gear (a) of type BS40 (for T90 only) or BS50 (for T130 only) an intermediate flange (b) must be used. There is no flange available for T60.

2.7 Installation of magnetic sensors

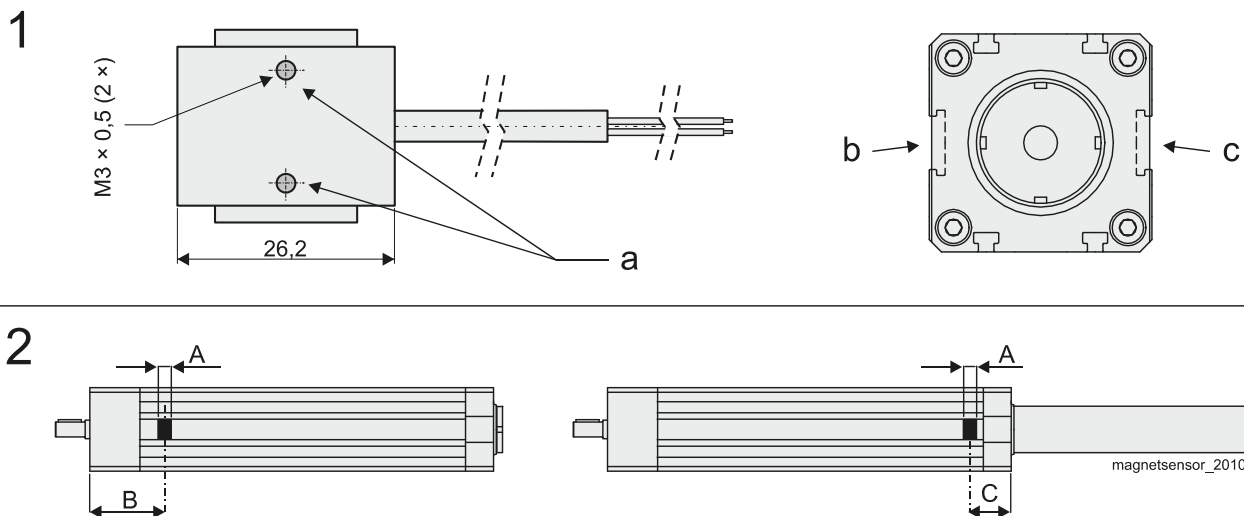

Figure 8: magnetic sensor

1. The sensors are locked in the desired position with the aid of the lock screws (a) in the T-slot. On T60 there is only one T-slot for sensors (b) while T90 and T130 has twp (b and c).
2. Magnet positions at fully retracted and fully extended rod. Keep in mind that the duration of the sensor signal is dependent upon the speed and the width of the magnet (the signal is somewhat longer than the magnet due to the spread of the magnetic field). This means that the relay or input device, which shall detect the signal, must be capable of detecting the duration of the signal in question.

	A	B	C
T06-B2505, T06-B2525 (T06-B2510, T06-B2550)	5	55	118 (140)
T09-B25	8	68	141
T09-B32	8	82	162
T13-B40	24	194	84
T13-B50	24	324	100

Table 4: magnet positions

3. Service and maintenance

3.1 General maintenance instructions

- The customer can perform the service and maintenance described in this manual. Other service ought to be performed by authorised personnel / service workshop.
 - Follow the recommended service intervals. Replace defective parts immediately. Only use parts of the same make and type as original. Ordering data can be found in the spare part lists supplied with the unit. Also state the manufacturing number of the unit (embossed in the drive end).
 - T90 and T130 is not self-braking. This means that the load and the extension tube can move if the driving force is disconnected, or if the motor, gears or brakes are detached during service. This is even more important for vertical applications. Ensure therefore that the load is secured before service is begun.
 - Check the unit in connection to lubrication. Be attentive towards the wear and function of the rod seal, the magnetic sensors, limit switches and the mounting of them. Check all connections to the support and the rod. Also be attentive towards a changed level of noise. Replace, repair or adjust.
 - Keep the actuator clean. Wipe it off as required, particularly the rod. If cleaning fluid is required, use small amounts and see to it that none gets into the actuator. Do not use strong cleaning agents. Dry it fully.
 - **Never** mix different types of oils / lubricants!
-

3.2 Lubrication of the ball screw

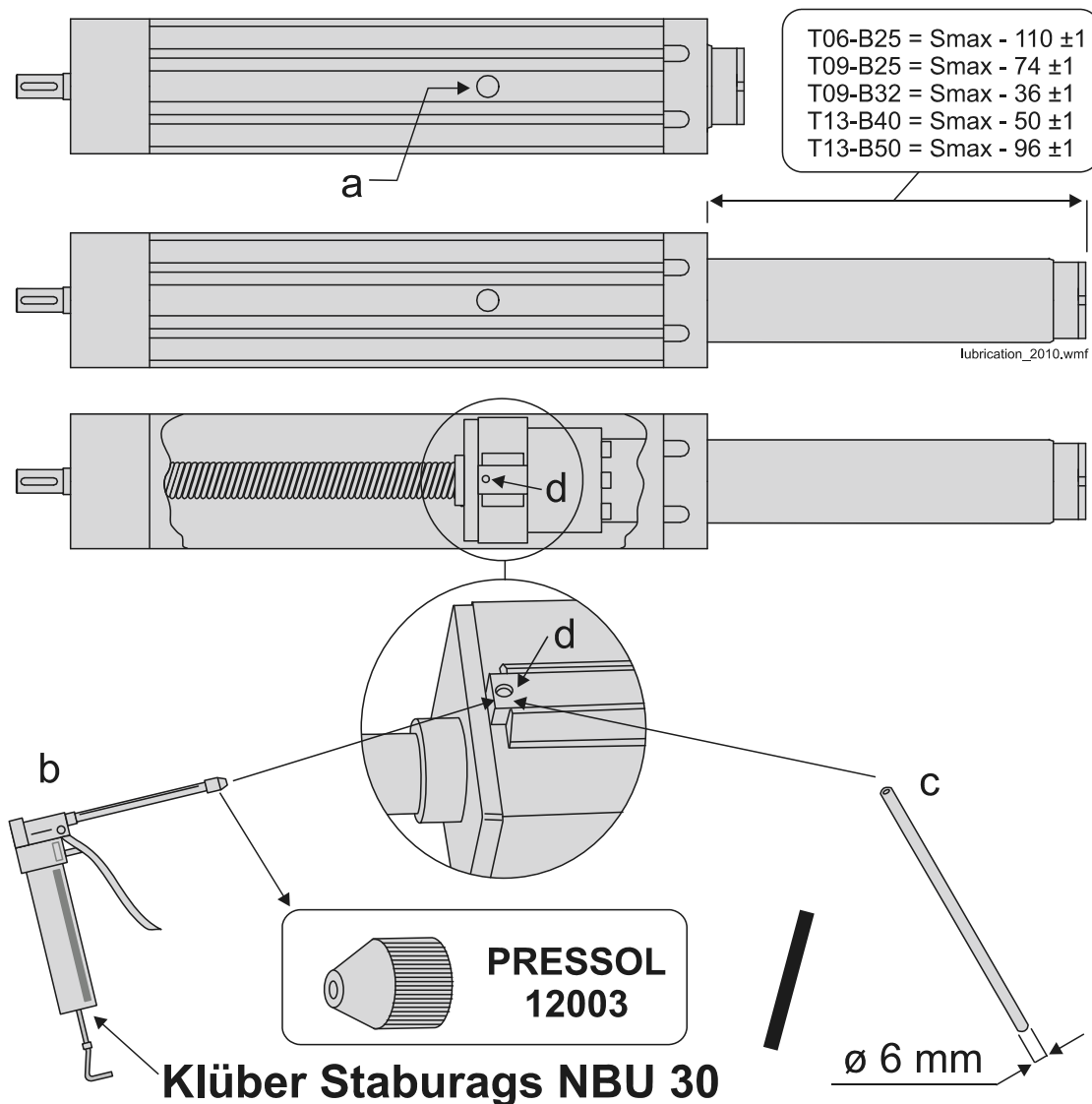

Figure 9: lubrication of the ball screw

1. The ball screw is lubricated every 600 hours of operation or every 6:th month depending on whichever comes first.
2. Recommended lubricant is Klüber Staburags NBU 30.
3. Remove the plastic plug covering the lubrication hole (a).
4. Run the extension tube to the indicated position for the actuator model in question. For T06-B25 the lubrication position is at the maximum stroke length (S_{max}) of the unit – 110 mm, for T09-B25 it is at S_{max} – 74 mm, for T09-B32 at S_{max} – 36, for T13-B40 at S_{max} – 50 mm and for T13-B50 at S_{max} – 96 mm.
5. Apply 20 ml of lubricant to the ball nut by sticking a grease gun nipple (b) or a tube (c), through which the lubricant can be applied, straight in to the lubrication hole in the profile so that it enter the lubrication hole (d) of the ball nut assembly. Recommended type of grease gun nipple is Pressol pointed coupler M10 x 1 female article no: 12003 or equivalent. If a tube is used the recommended tube diameter is 6 mm.
6. Pull out the grease gun nipple / tube and put back the plastic plug.

4. Technical data

4.1 Technical data

		T06-B2505M ••••	T06-B2510M ••••	T06-B2525M ••••
Max. speed	[m/s]	0,25	0,66	1,66
Max. radial load	Fr [N]	100	100	100
Max. axial load	Fx [N]			
static		15 000	15 000	15 000
dynamic		10 000	10 000	10 000
Repeatability	[mm]	± 0,05	± 0,05	± 0,05
Max. input speed	[rpm]	3000	4000	4000
Weight	[kg]	$5 + (L^A \times 9,5)$	$5 + (L^A \times 9,5)$	$5 + (L^A \times 9,5)$
Ambient temperature	[°C]	-20 – +70	-20 – +70	-20 – +70
Linear move / shaft turn	[mm]	5	10	25

		T06-B2550M ••••	T09-B2510M ••••	T09-B2525M ••••
Max. speed	[m/s]	2,5	0,8	1,5
Max. radial load	Fr [N]	100	300	300
Max. axial load	Fx [N]			
static		15 000	15 000	15 000
dynamic		10 000	10 000	10 000
Repeatability	[mm]	± 0,05	± 0,05	± 0,05
Max. input speed	[rpm]	3000	4800	4800
Weight	[kg]	$5 + (L^A \times 9,5)$	$5 + (L^A \times 16,2)$	$5 + (L^A \times 16,2)$
Ambient temperature	[°C]	-20 – +70	-20 – +70	-20 – +70
Linear move / shaft turn	[mm]	50	10	25

		T09-B3220M ••••	T09-B3232M ••••	T13-B4010M ••••
Max. speed	[m/s]	1,25	2	0,4
Max. radial load	Fr [N]	500	500	800
Max. axial load	Fx [N]			
static		25 000	25 000	45 000
dynamic		20 000	20 000	40 000
Repeatability	[mm]	± 0,05	± 0,05	± 0,05
Max. input speed	[rpm]	3750	3750	2500
Weight	[kg]	$6,5 + (L^A \times 18)$	$6,5 + (L^A \times 18)$	$18,5 + (30 \times (L^A - 0,239))$
Ambient temperature	[°C]	-20 – +70	-20 – +70	-20 – +70
Linear move / shaft turn	[mm]	20	32	10

		T13-B4020M ••••	T13-B4040M ••••	T13-B5010M ••••
Max. speed	[m/s]	1	2	0,33
Max. radial load	Fr [N]	800	800	800
Max. axial load	Fx [N]			
static		45 000	45 000	80 000
dynamic		35 000	15 000	60 000
Repeatability	[mm]	± 0,05	± 0,05	± 0,05
Max. input speed	[rpm]	3000	3000	2000
Weight	[kg]	$18,5 + (30 \times (L^A - 0,239))$	$18,5 + (30 \times (L^A - 0,239))$	$31,8 + (L^A \times 35)$
Ambient temperature	[°C]	-20 – +70	-20 – +70	-20 – +70
Linear move / shaft turn	[mm]	20	40	50

^A L in metres, see figure 1 for definition of L

Table 5: technical data

United Kingdom

Thomson
Fishleigh Road
Barnstaple
EX31 3UD, United Kingdom
Phone: +44 (0)1271 334 500
Fax: +44 (0)1271 334 501
E-mail: sales.uk@thomsonlinear.com

Germany

Thomson
Nürtinger Straße 70
72649 Wolfschlügen, Germany
Phone: +49 (0) 7022 504 100
Fax: +49 (0) 7022 504 405
E-Mail: sales.wolfschlügen@thomsonlinear.com

Sweden

Thomson
Box 9053
SE-291 09 Kristianstad, Sweden
Phone: +46 (0) 44-24 67 00
Fax: +46 (0) 44-24 40 85
E-mail: sales.scandinavia@thomsonlinear.com

Italy

Thomson
Largo Brughetti
I-20030 Bovisio Masciago, Italy
Phone: +39 0362 594260
Fax: +39 0362 594263
E-mail: info@thomsonlinear.it

France

Thomson
C.P 80018
12, Rue Antoine Becquerel – Z.I. Sud
F-72026 Le Mans Cedex 2, France
Phone: +33 (0) 243 50 03 30
Fax: +33 (0) 243 50 03 39
E-mail: sales.france@thomsonlinear.com

Spain

Thomson
Rbla Badal, 29-31 7th, 1st
08014 Barcelona, Spain
Phone: +34 (0) 9329 80278
Fax: +34 (0) 9329 80278
E-mail: josep.estaran@thomsonlinear.com



Linear Motion. Optimized.

