



## Electrak<sup>®</sup> HD

Linear Actuator with Flexible Onboard Controls, Superior Performance and Unmatched Environmental Protection

## Electrak® HD – Superior Performance Linear Actuator

Higher power, longer stroke, onboard controls with optional J1939 CAN bus and unmatched environmental protection

The Electrak HD is a new electric linear actuator platform with onboard electronics, which can eliminate the need for standalone controls. Higher power opens a new, wider range of hydraulic applications to electric conversion. And it meets the most extreme OEM component environmental acceptance tests, including IP69K.

### Industry-Leading, Onboard Electronics

The new Electrak Modular Control System (EMCS) is the foundation for the best onboard controls currently available in electric linear actuators and includes optional, built-in J1939 CAN bus support.

The feature-rich modular design for all control and feedback options is simple to use and built within one compact housing. It improves controllability, saves space and reduces installation time and total cost.

- Built-in J1939 CAN bus option enhances controllability, can eliminate individual controls and simplifies OEM machine design
- Electronic trip point calibration ensures consistent overload protection
- Constant monitoring of critical parameters such as end-of-stroke, voltage, current and temperature is standard on all HD actuators
- Built-in dynamic braking reduces coast at the end of stroke, improving repeatability
- Optional low-level switching with automatic sleep mode reduces footprint, lowers costs and boosts circuit isolation
- Optional end-of-stroke indication output for customer use, such as interlocks

### Superior Performance

Higher power and longer stroke lengths enable Electrak HD to tackle applications outside the range of other electric linear actuators.

- Higher load ranges up to 10 kN (2250 lbs.) are ideal for hydraulic-to-electric conversion applications
- Stroke lengths up to 1000 mm (39 in.)
- Efficient actuator design, including a high-quality ball screw, reduces current draw by up to 20%



### Unrivalled Environmental Protection

Electrak HD is tested to meet and exceed the toughest OEM mechanical and electronic component acceptance tests on the market today.

- IP69K (static), IP67 (static) and IP66 (dynamic) ratings prove Electrak HD can withstand the harshest environments
- Capable of operating in a wide temperature range from -40°C to +85°C (-40°F to +185°F)
- Salt spray tested for 200 hours
- CE, RoHS and REACH (EU) compliant

### Additional Standard Features

- Integrated manual override
- Standard anti-rotation actuation
- Integrated thermal overload protection
- Load lock in case of ball nut overload failure
- Flexible front and rear clevis options



## How Thomson Built a World-Class Linear Actuator

1. Start with the proven, rugged Electrak® electric linear actuator.
2. Add state-of-the-art onboard controls, feedback, J1939 CAN bus and eliminate the need for standalone controls.
3. Boost the power, increase stroke lengths and reduce current draw.
4. Design it all into a more compact envelope with the best environmental protections on the market today.

### INDUSTRY-LEADING ONBOARD CONTROLS

The new Electrak Modular Control System is the foundation of the best onboard controls available today for electric linear actuators and includes optional, built-in J1939 CAN bus support.

#### 1 Electrak Modular Control System (EMCS)

- Electrak Monitoring Package (standard)
- End-of-Stroke Indication Output Option
- Analog Position Output Option
- Digital Position Output Option
- Low-Level Signal Motor Switching Option
- J1939 CAN Bus Control Option

#### 2 Built-in End-of-Stroke Limit Switches

#### 3 Mounting Slots for External Limit Switches



## SUPERIOR PERFORMANCE

Higher power and longer stroke lengths enable Electrak HD to tackle applications outside the range of other electric linear actuators.

- 4** Modular Cabling
- 5** Standard Anti-Rotation Feature
- 6** Static Load Holding Brake
- 7** Robust Zinc Housing
- 8** Large Variety of Adapters
- 9** Integrated Manual Override
- 10** High-Efficiency Ball Screw Assembly

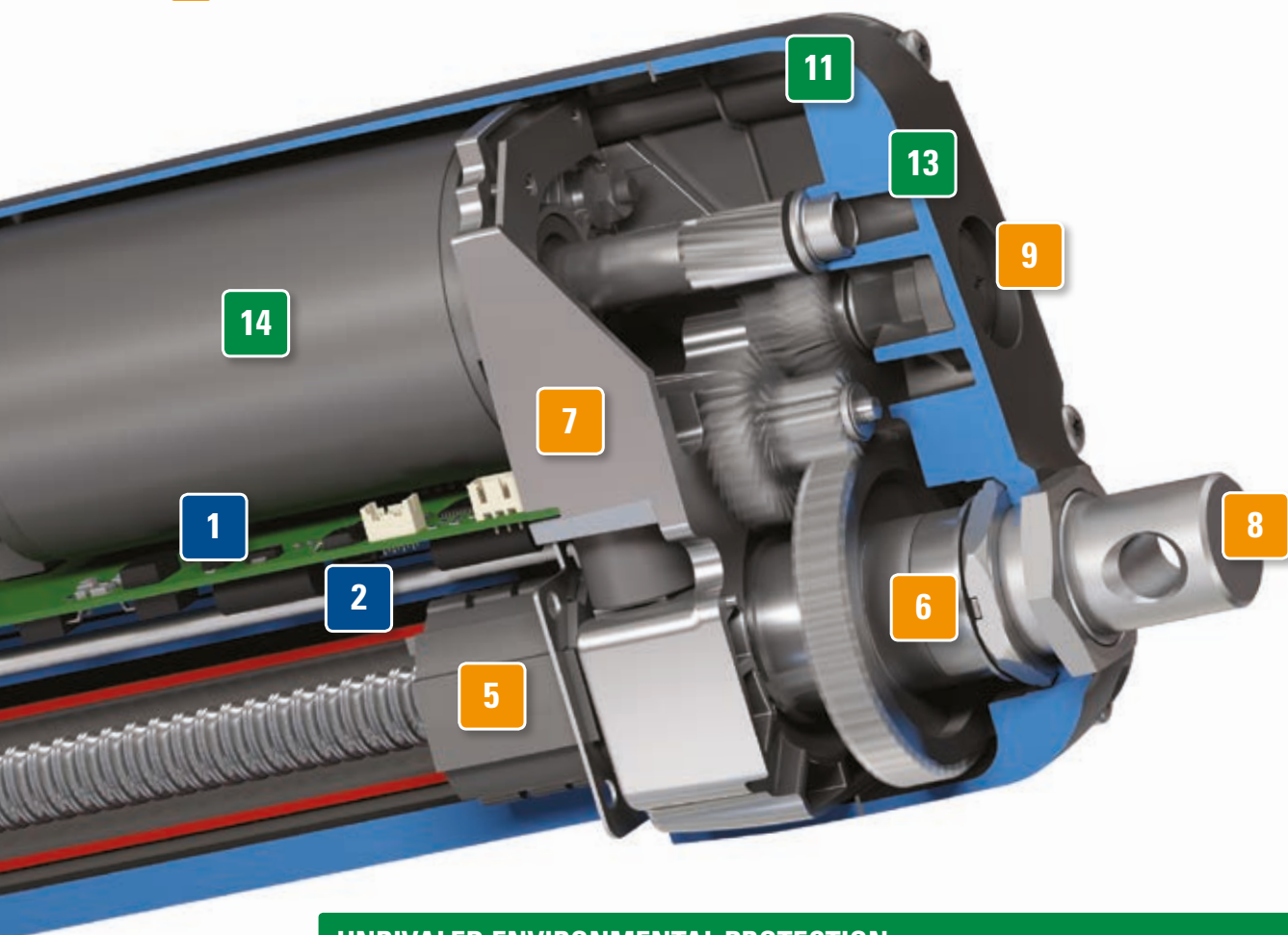

## UNRIVALED ENVIRONMENTAL PROTECTION

Electrak HD is tested to meet and exceed the toughest OEM mechanical and electronic component acceptance tests on the market today.

- 11** IP67/IP69K Protection Class
- 12** Stainless Steel Extension Tube
- 13** Salt Spray Tested for 200 Hours
- 14** Large Operating Temperature Range
- 15** Hard-Coat Anodized Aluminum Cover Tube

## Smart Onboard Electronics for Easier Control

Thomson's Electrak Modular Control System (EMCS) is built into every HD actuator and serves as the foundation for the best onboard controls currently available on the market, including optional J1939 CAN bus.

### Industry-Leading Onboard Electronics

EMCS is the culmination of decades of global design and application engineering in some of the toughest environments.

### Electronic Monitoring Package – Standard on all Electrak HD Actuators

Safety comes first. Each HD electric linear actuator is equipped with the Electrak Monitoring Package, which will constantly monitor critical parameters and take appropriate action as needed. Each unit will reset automatically when conditions return to normal, allowing for operation to continue.

### A Wide Range of Optional Control Features Within the Same Compact Envelope

Optional control functions can eliminate the need for external controls, saving design and installation time, as well as space and installed cost. A generous selection of control configurations can tailor HD to fit a wide breadth of heavy duty applications. The available control configurations are described on the next page and more details, including wiring diagrams for each option, begin on page 22.



## Electrak Monitoring Package Standard Features

### Current Monitoring

A critical safety feature that shuts down the actuator on overload and eliminates the need for the traditional noisy mechanical clutch.

### Voltage and Temperature Monitoring

Continuous monitoring protects the actuator by preventing motion if outside normal ranges.

### Temperature Compensation

Boosts productivity by enabling normal operation at lower temperatures without nuisance tripping.

### Load Trip Point Calibration

Each Electrak HD actuator is individually calibrated at assembly to ensure a repeatable overload trip point.

### Internal End-of-Stroke Limit Switches

Built in to each HD actuator, they ensure smooth, repeatable operation and protect both connected equipment and the actuator.

### End-of-Stroke Dynamic Braking

Enable quick end-of-stroke stops, putting less stress on the internal mechanical parts.

## Optional Control Features

### J1939 CAN Bus

Allows plug and play connectivity on your already established J1939 network.

### Mid-Stroke Dynamic Braking

Standard with the low-level switching or CAN bus options. Reduces coast, improving repeatability.

### Low-Level Switching

Improves safety and simplifies design by using low current (< 22 mA) signals. Also saves energy with an auto sleep feature.

### Limit Switch Output

Confirms successful operation by indicating the actuator is fully extended or retracted.

### Analog Position Output

A high-quality potentiometer with essentially infinite resolution and low noise provides a voltage signal for position and direction feedback.

### Digital Position Output

An encoder provides a single-channel pulse train for position and speed feedback, which can be used to allow synchronization via customer control.

## Control Option Combinations

Code	Control Combination Possibilities	Code	Control Combination Possibilities
EXX	Electrak Monitoring Package only	LXX	EXX + Low-Level Signal Motor Switching
ELX	EXX + End-of-Stroke Indication Output	LLX	EXX + LXX + End-of-Stroke Indication Output
EXP	EXX + Analog Position Output	LXP	EXX + LXX + Analog Position Output
EXD	EXX + Digital Position Output	CNO	J1939 CAN Bus Control + Open-Loop Speed Control
ELP	ELX + Analog Position Output		
ELD	ELX + Digital Position Output		

## Bus Communication – The Future of Actuator Control

Controlling an actuator over a network bus opens the door to breakthrough opportunities in machine design. More control, monitoring and feedback options can eliminate the need for separate controls. These options will also simplify design, diagnostic feedback and installation while reducing installed costs.

The built-in CAN bus option makes it possible to communicate with Electrak® HD electric linear actuators over a simple two-wire network.

### **CAN Bus in Practice**

Electrak HD uses J1939 CAN bus, a well-known, mature bus standard widely used in the construction and agriculture industries. Up to 16 Electrak HD actuators can be connected to the same controller and to other CAN bus controls in the network.

Complex, real-time interactions between multiple actuators and related systems are now much simpler to monitor and control.

### **Application Examples**

- Check position of doors and hatches and take action depending on the situation
- Monitor the temperature, overload condition or voltage variations, then take action across the network as needed. Examples: start ventilation, reduce speed or stop an operation.
- Confirm when position or other criteria are met
- Synchronize the motion of several actuators

The word 'CAN' is written in a large, bold, green, sans-serif font. The letters are closely spaced and have a slight shadow effect, giving them a three-dimensional appearance. The 'C' is a simple curve, the 'A' has a vertical bar on the right, and the 'N' is a simple vertical stroke with a diagonal crossbar.

### **Benefits of CAN Bus Controls**

- Better controllability – more complex, precisely controlled motion
- Improved safety – feedback in real-time with all operations verified
- Shorter design cycles and installation time – CAN bus means minimal wiring, no extra control boxes and quick connection to existing networks
- Greater flexibility – use the same actuator with minor program edits for multiple applications instead of designing for unique actuators and controls for every type of application
- Reduced costs – all of the above will lead to reduced design, component, installation, operation and maintenance costs



# Control Architecture With and Without CAN Bus

## System Without CAN Bus

- A power (1) is distributed to each device
- A main control (2) system communicates separately with an individual control (3) box connected to an actuator. Each instance may require individual design, configuration, wiring and installation.
- Other equipment (4) that needs to be controlled or integrated with the actuators requires separate controls with more design and configuration required

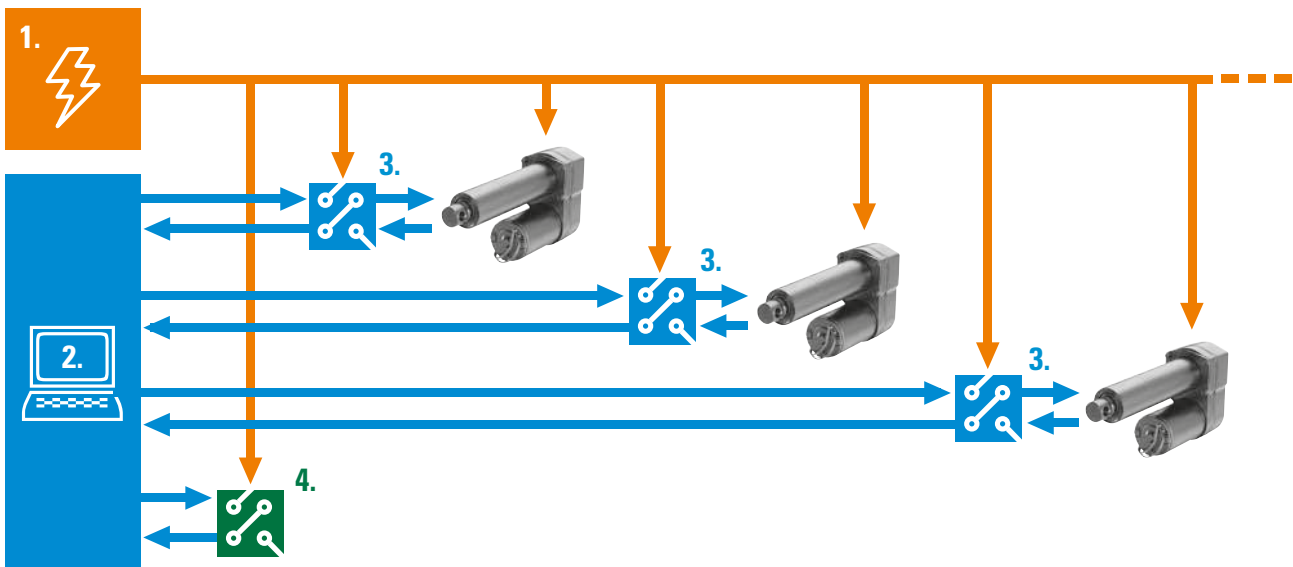

## System With CAN Bus

- A control system and actuators with CAN bus can communicate directly to each other. Adding additional, separately configured actuators is fast and easy. Only the power and a two-wire bus cable are needed to extend the network.
- Any other equipment with CAN bus can be connected to the bus and communicate directly
- The result is a less complex system to design, better performance and controllability, and reduced installation time and overall cost

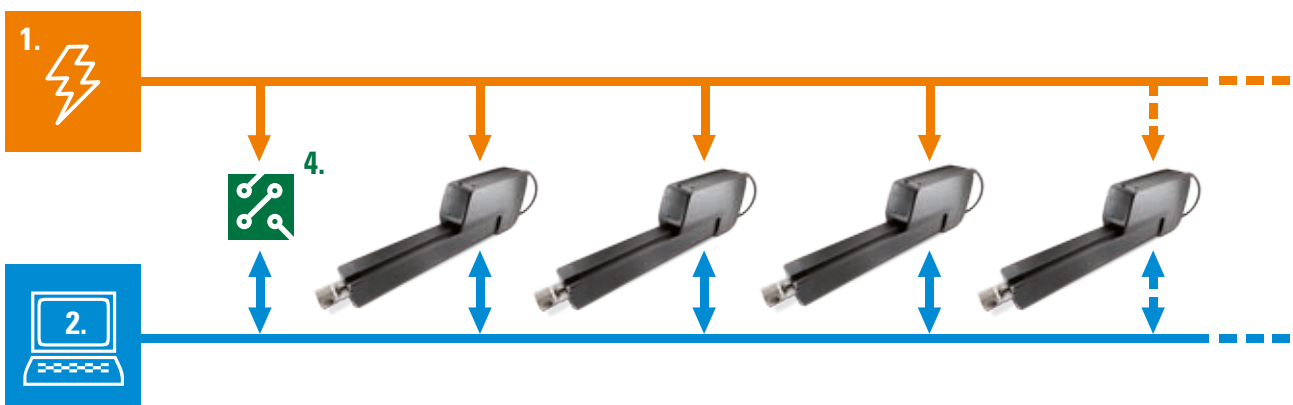

## Electrak® HD – Smarter, Stronger, Longer

In addition to advanced control features, the Electrak HD offers 50% higher load capacity and 60% longer stroke lengths than previous designs, and is faster than the competition at comparable loads. This new, extended envelope of operation also opens a larger range of hydraulic-to-electric application conversions.



Electrak HD offers smart design solutions, like built-in cable management, an integrated connector and a manual override feature on every actuator.



Building on the capabilities of the Electrak 10, the workhorse of electric actuators for decades, the Electrak HD offers onboard controls, higher load



capacity (up to 10 kN [2250 lbs.]), longer strokes (up to 1 m [39 in.]) and higher speeds.

## Ready to Work in Extreme Environments

The Electrak HD is well suited for heavy duty, industrial applications, including conversion of hydraulic to electric actuation. It shows its mettle when used under the harshest conditions. Each HD actuator is designed to meet and exceed the toughest OEM mechanical and electrical components tests, including IP69K.



## Accelerated Trend Toward Electric Conversions

Once dominated by manual, pneumatic and hydraulic systems, mobile on- and off-highway equipment is increasingly equipped with electric actuators to automate many tasks. Electric linear actuators are easier to integrate with modern computer-based control systems and are precisely controlled. They consume a smaller footprint and are cleaner than both pneumatic and hydraulic systems.

### **Converting to Electric Immediately Eliminates:**

- the cost and bulk of pumps, valves and hoses.
- environmentally hazardous oil and leaks.
- costly hydraulic reliability issues and contamination.
- the high-energy consumption of pneumatic and hydraulic systems.
- nuisance start-up failures in cold temperatures.

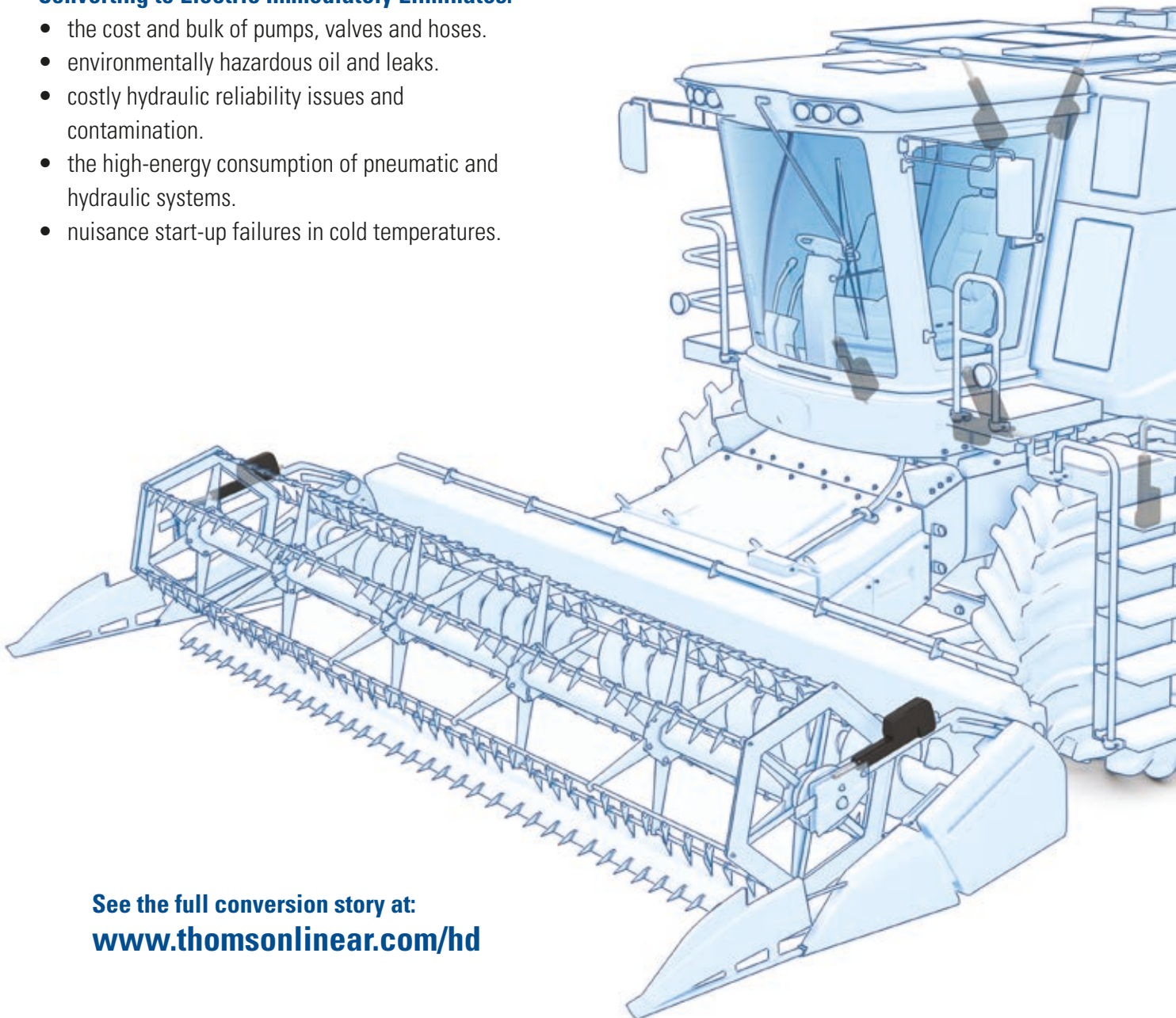

See the full conversion story at:  
[www.thomsonlinear.com/hd](http://www.thomsonlinear.com/hd)

## Easier Installation, Superior Control and Less Complexity

### Simpler, Smaller and Faster to Install

- Electric actuation requires fewer components than hydraulic or pneumatic systems for faster and easier installation
- Component costs are less than in comparable hydraulic or pneumatic systems
- A smaller footprint simplifies and speeds design

### Easier Control, Better Accuracy

- All-electric components mean easier integration, fewer control components and less complexity
- Electric actuators react quicker and more predictably, and will not drift when power is off

### Lower Energy Costs

- Electric motors are intrinsically more efficient than pneumatic or hydraulic motors
- No need to up-size the existing system to account for potential parasitic power draw
- No power required to hold load-reducing power consumption

### Less Maintenance

- No hydraulic pumps, valves or hoses means reduced downtime with fewer parts to service and replace
- Self-contained units with smart, onboard electronics require zero maintenance, adding design flexibility in component placement
- Electric actuation eliminates the cost and hassle associated with fluid maintenance

### Cleaner, Quieter, Healthier Environment

- No pumps, fluids, chemicals or solvents translates into a cleaner and quieter workspace
- A compact design requires fewer materials to be used in production
- Regional manufacturing and distribution plants minimize freight and reduce the carbon footprint

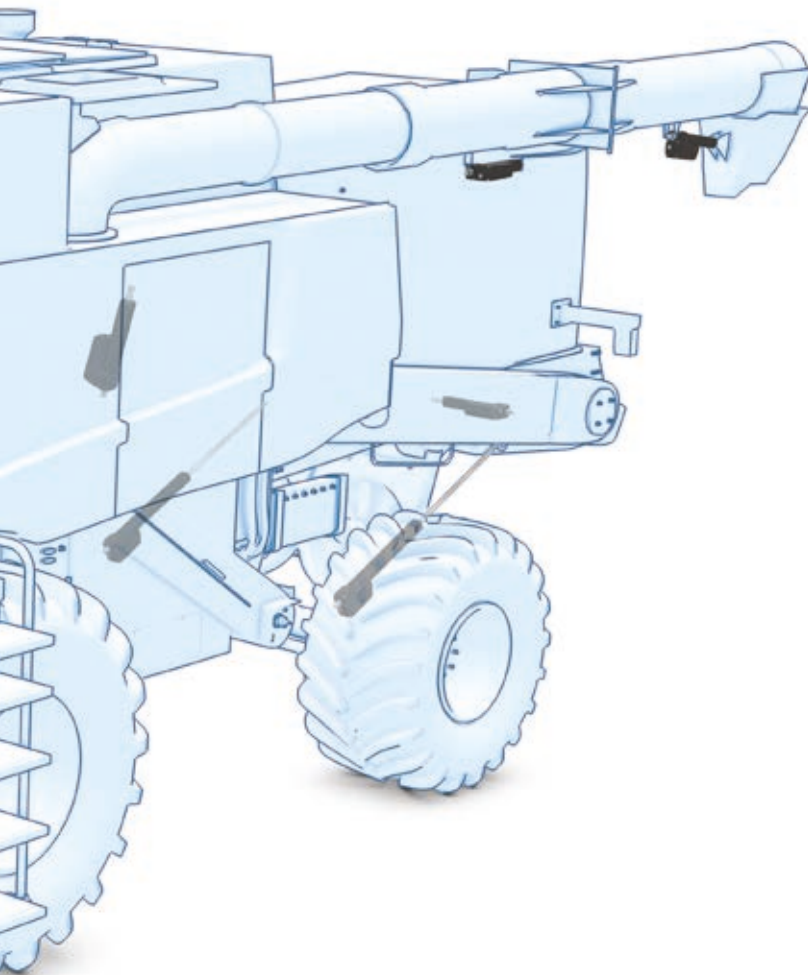

## Improving Machine Design with Electric Actuation

These applications illustrate how the Electrak® HD can deliver huge benefits over pneumatic and hydraulic mechanisms, including reduced design, installation and operation costs, while improving controllability, safety and productivity.

### Single-User Maintenance and Repair

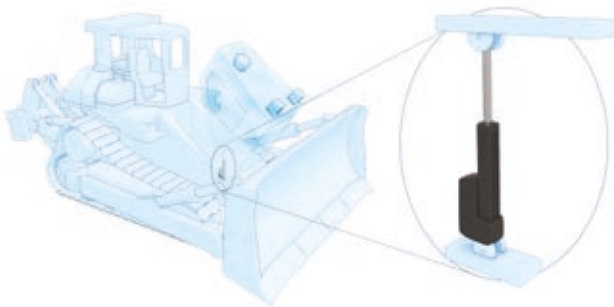

Electric linear actuators enable a single maintenance or repair technician to access the engine compartment quickly and safely.

### Quick-Attach

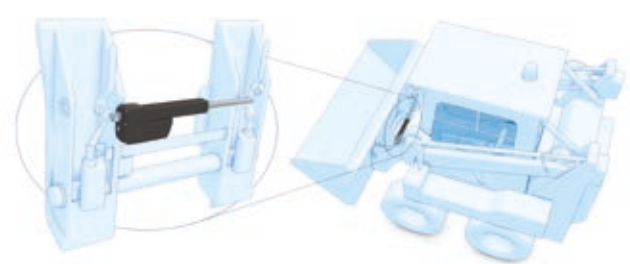

Quick-attach actuators allow the operator to change implements on the loader or skid steer without leaving the seat for improved productivity and safety.

### Utility Vehicles

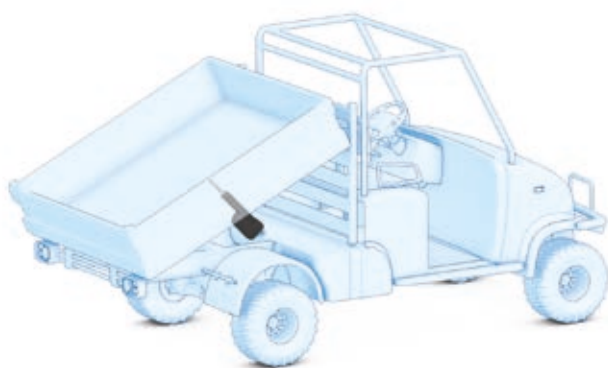

Garden, construction and service vehicles require rugged, efficiently controlled performance. The environmental protection (IP69K), high load capabilities and J1939 CAN bus communication provide that performance.

### Roadwork and Construction Site Equipment

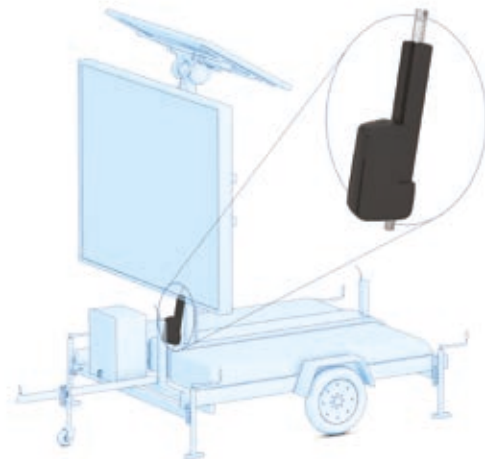

Long stroke, protection against harsh environments and high load rating (including high shock loading for wind shear) make the Electrak HD a great fit for this roadside construction sign.

## Railroad Equipment

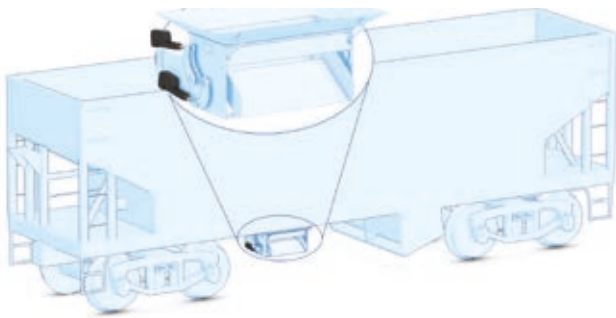

Railroad equipment experiences the toughest conditions. Whether it is to open and close a gravity bin or to control a pantograph, the Electrak HD actuator will perform effectively despite harsh weather, heavy vibrations or high-pressure washing.

## Logistic Systems

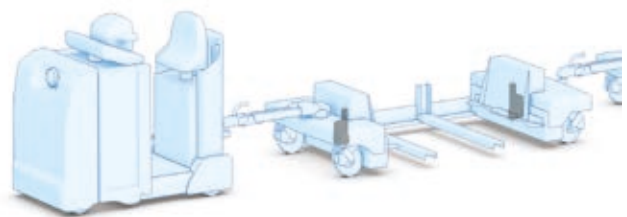

The Electrak HD, with its built-in J1939 CAN bus capabilities, makes it easy to build intelligent logistic systems such as the material handling train shown here.

## Emergency and Rescue Vehicles

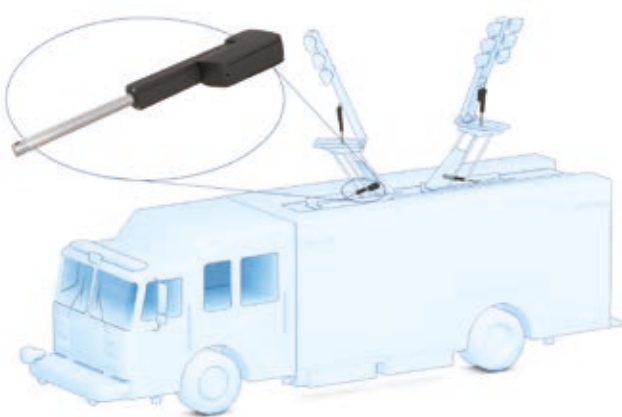

The deployment of lighting on emergency vehicles demands the most reliable operation. Electrak HD is easily controlled, has a built-in manual override and operates reliably in all weather to help emergency responders perform their jobs safely.

## Switch Gears

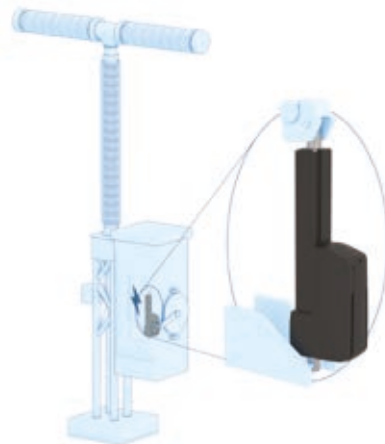

Electrical switch gears are often placed in remote locations. It is critical that power switching is executed and confirmed without fail. Electrak HD is ideal for this task in arctic to high-temperature conditions.

# Electrak® HD Technical Features



## The Thomson Electrak HD is a New Electric Linear Actuator Platform

Onboard electronics eliminate the need for standalone controls. Higher power opens a new, wider range of hydraulic-to-electric application conversions. And the Electrak HD meets the most extreme OEM component environmental acceptance tests, including IP69K.

General Specifications	
Parameter	Electrak HD
Screw type	ball
Nut type	load lock ball nut
Manual override	yes
Anti-rotation	yes
Dynamic braking	yes <sup>(1)</sup>
Static load holding brake	yes
End-of-stroke protection	internal end-of-stroke limit switches
Overload protection	yes
Temperature monitoring	yes
Temperature compensation	yes
Voltage monitoring	yes
Electrical connections <sup>(2)</sup>	cable(s) with flying leads
Compliance	CE

(1) Dynamic braking is included at the ends of stroke for all Electrak HD actuators. Dynamic braking offered throughout the entire stroke length only on low-level switching and J1939 options.

(2) There are one or two cables depending on the control option used. The cable(s) enters the actuator via a connector. The replacement of an actuator can be completed by unplugging the old actuator and plugging in the new one.

Optional Features	
Parameter	Electrak HD
Mechanical options	Variety of front and rear adapters
	Alternative adapter orientation
Control options (see page 22)	End-of-stroke output
	Analog position feedback
	Digital position feedback
	Low-level signal motor switching
	J1939 CAN bus

Accessories	
Parameter	Electrak HD
Mechanical	Rod end front adapter
Electrical	External slot-mounted limit switches



# Electrak HD Technical Specifications

Mechanical Specifications		
Parameter		Electrak HD
Max. static load <sup>(1)</sup>	[kN (lbs)]	18 (4050)
Max. dynamic load (Fx)	[kN (lbs)]	
HDxx-B017		1.7 (382)
HDxx-B026		2.6 (585)
HDxx-B045		4.5 (1012)
HDxx-B068		6.8 (1529)
HDxx-B100		10 (2248)
Speed @ no load/max. load	[mm/s (in/s)]	
HDxx-B017		71/58 (2.8/2.28)
HDxx-B026		40/32 (1.6/1.3)
HDxx-B045		24/19 (0.94/0.75)
HDxx-B068		18/14 (0.71/0.55)
HDxx-B100		11/9 (0.43/0.35)
Min. ordering stroke (S) length	[mm]	100
Max. ordering stroke (S) length	[mm]	1000
Ordering stroke length increments	[mm]	50
Operating temperature limits	[°C (F)]	-40–85(-40–185)
Full load duty cycle @ 25 °C (77 °F)	[%]	25 <sup>(2)</sup>
End play, maximum	[mm (in)]	1.2 (0.047)
Restraining torque	[Nm (lbs)]	0
Protection class - static		IP67 / IP69K
Protection class - dynamic		IP66
Salt spray resistance	[h]	200

<sup>1</sup> Max. static load at fully retracted stroke.

<sup>2</sup> For a HDxx-B1000 actuator, unidirectional load, the duty cycle is 15%.

Electrical Specifications		
Parameter		Electrak HD
Available input voltages	[Vdc]	12, 24
Input voltage tolerance	[Vdc]	
HD12 (12 Vdc input voltage)		9 - 16
HD24 (24 Vdc input voltage)		18 - 32
Current draw @ no load/max. load	[A]	
HD12-B017		3/18
HD24-B017		1.5/9
HD12-B026		3/18
HD24-B026		1.5/9
HD12-B045		3/18
HD24-B045		1.5/9
HD12-B068		3/20
HD24-B068		1.5/10
HD12-B100		3/18
HD24-B100		1.5/9
Motor leads cross section	[mm <sup>2</sup> (AWG)]	2 (14)
Signal leads cross section	[mm <sup>2</sup> (AWG)]	0.5 (20)
Standard cable lengths (Ca1)	[m (in)]	0.3, 1.5, 5 (11.8, 59, 197)
Cable diameter (Ca2)	[mm (in)]	7.5 (.295)
Flying lead length (Ca3)	[mm (in)]	76.2 (3)
Stripped lead length (Ca4)	[mm (in)]	6.35 (0.25)

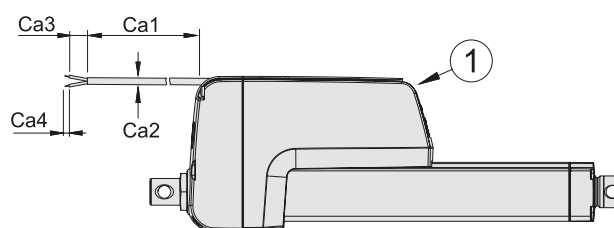

The drawing shows the cables exiting the cable slots at the end of the actuator housing, which is the shipping position. The user can adjust the exit point to be anywhere between the connector (1) in the front of the housing and the end of the cable slots.

Actuator Weight [kg]																			
Maximum Dynamic Load (Fx) [kN (lbs)]	Ordering Stroke (S) [mm]																		
	100	150	200	250	300	350	400	450	500	550	600	650	700	750	800	850	900	950	1000
1.7 (382)	6,5	6,7	7,0	7,2	7,5	7,7	8,0	8,2	8,5	8,7	9,0	9,2	9,5	9,7	10,0	10,2	10,5	10,7	11,0
2.6 (585)	6,5	6,7	7,0	7,2	7,5	7,7	8,0	8,2	8,5	8,7	9,0	9,2	9,5	9,7	10,0	10,2	11,6	11,9	12,2
4.5 (1012)	6,5	6,7	7,0	7,2	7,5	7,7	8,0	8,2	8,5	8,7	9,0	9,2	10,4	10,7	11,0	11,3	11,6	11,9	12,2
6.8 (1592)	6,5	6,7	7,0	7,2	7,5	7,7	8,0	8,2	8,5	9,5	9,8	10,1	10,4	10,7	11,0	11,3	11,6	11,9	12,2
10 (2248)	6,7	7,0	7,2	7,5	7,7	8,0	8,2	9,1	9,4	9,7	10,0	10,3	10,6	10,9	11,2	11,5	11,8	12,1	12,4

Conversion Factors: Millimeter to inch: 1 mm = 0.03937 in, kilogram to pound: 1 kg = 2.204623 lbs

## How to Order the Electrak® HD

This ordering key provides a quick overview of the product versions available. It is important to consider many application details when selecting a product, including the loads, speeds and control options required, as well as the product environment and necessary accessories. To explore additional technical resources and options, contact Thomson customer support at [www.thomsonlinear.com/hd](http://www.thomsonlinear.com/hd).

Ordering Key							
1	2	3	4	5	6	7	8
<b>HD12</b>	<b>B026-</b>	<b>0300</b>	<b>LXX</b>	<b>2</b>	<b>M</b>	<b>M</b>	<b>S</b>
<p><b>1. Model and input voltage</b> HD12 = Electrak HD, 12 Vdc HD24 = Electrak HD, 24 Vdc</p> <p><b>2. Screw type, dynamic load capacity</b> B017- = ball screw, 1.7 kN (382 lbs) B026- = ball screw, 2.6 kN (585 lbs) B045- = ball screw, 4.5 kN (1012 lbs) B068- = ball screw, 6.8 kN (1529 lbs) B100- = ball screw, 10 kN (2248 lbs)</p> <p><b>3. Ordering stroke length <sup>(1)</sup></b> 0100 = 100 mm 0150 = 150 mm 0200 = 200 mm 0250 = 250 mm 0300 = 300 mm 0350 = 350 mm 0400 = 400 mm 0450 = 450 mm 0500 = 500 mm 0550 = 550 mm 0600 = 600 mm 0650 = 650 mm 0700 = 700 mm 0750 = 750 mm 0800 = 800 mm 0850 = 850 mm 0900 = 900 mm 0950 = 950 mm 1000 = 1000 mm</p>				<p><b>4. Electrak Modular Control System options</b> EXX = Electronic Monitoring Package only ELX = EXX + end-of-stroke indication output EXP = EXX + analog (potentiometer) position output EXD = EXX + digital position output ELP = ELX + analog (potentiometer) position output ELD = ELX + digital position output LXX = EXX + low-level signal motor switching LLX = EXX + LXX + end-of-stroke indication output LXP = EXX + LXX + analog (potentiometer) position output CNO = J1939 CAN bus + open-loop speed control</p> <p><b>5. Harness option</b> 1 = 0.3 m long cables with flying leads 2 = 1.5 m long cables with flying leads 3 = 5.0 m long cables with flying leads</p> <p><b>6. Rear adapter option</b> M = cross hole for 12 mm pin E = cross hole for ½ inch pin N = forked cross hole for 12 mm pin F = forked cross hole for ½ inch pin</p> <p><b>7. Front adapter option</b> M = cross hole for 12 mm pin E = cross hole for ½ inch pin N = forked cross hole for 12 mm pin F = forked cross hole for ½ inch pin P = metric female thread G = inch female thread</p> <p><b>8. Adapter orientation</b> S = standard M = 90 ° turned</p> <p>(1) Other stroke lengths available upon request. Please contact customer support.</p>			

# Performance Diagrams

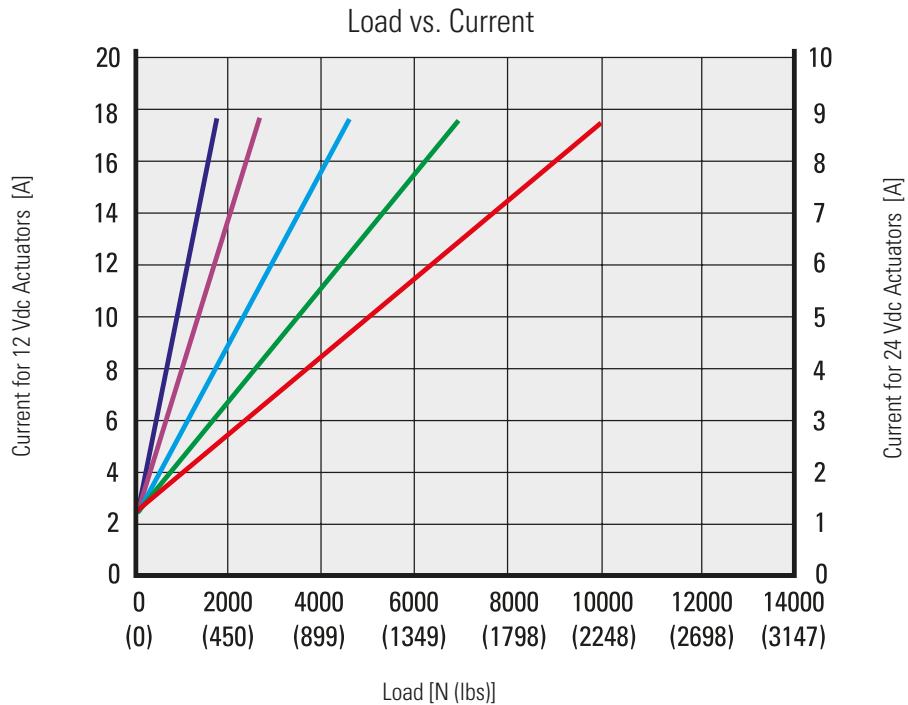
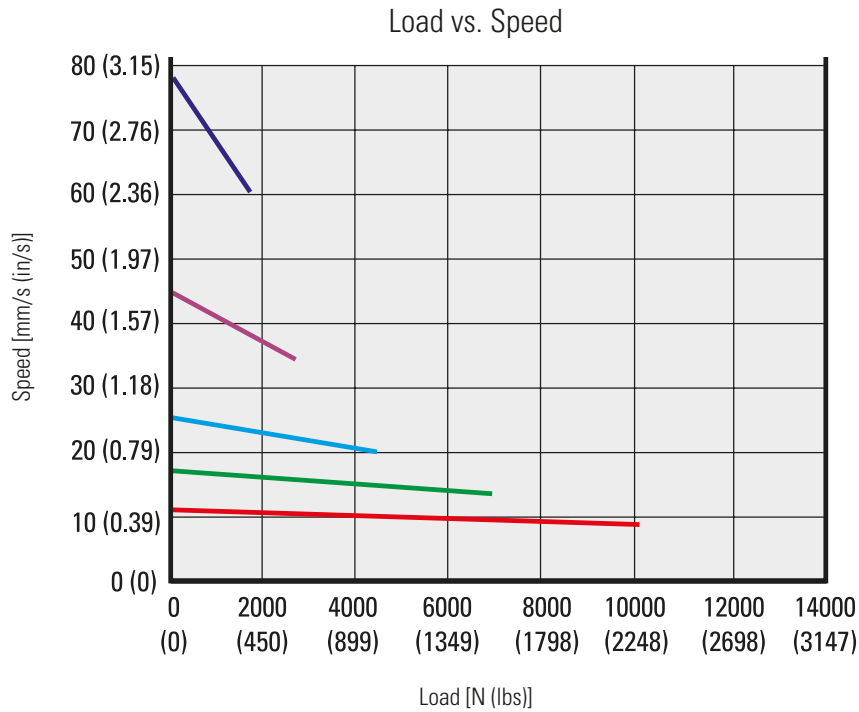

Screw Type and Dynamic Load Capacity

- ball screw, 1.7 kN (382 lbs) ■
- ball screw, 4.5 kN (1012 lbs) ■
- ball screw, 10 kN (2248 lbs) ■
- ball screw, 2.6 kN (585 lbs) ■
- ball screw, 6.8 kN (1529 lbs) ■

**Note!** Curves were generated at an ambient temperature of 21°C (70°F). Different ambient temperature and individual actuator characteristics can produce slightly different values.

# Dimensions

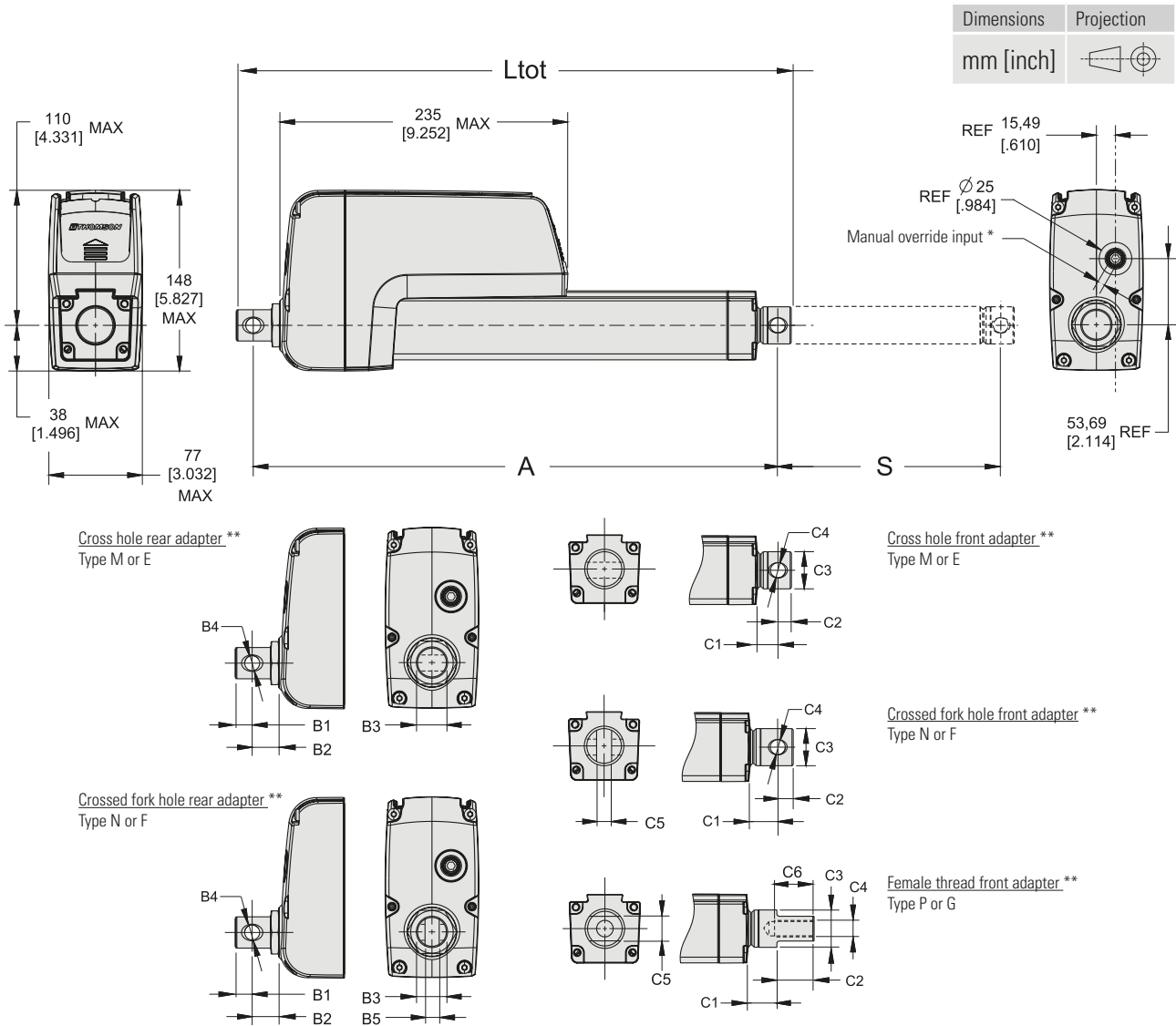

\* Manual override input. The input hole is covered with a plastic threaded plug. When removed, a 6 mm socket can be inserted and used as a crank.  
 \*\* All adapters shown in the standard orientation.

Rear Adapter Dimensions - mm (in.)				
	Adapter Type			
	M	E	N	F
B1	13.4 (0.53)	13.4 (0.53)	13.4 (0.53)	13.4 (0.53)
B2	21.6 (0.85)	21.6 (0.85)	21.6 (0.85)	21.6 (0.85)
B3	25.4 (1.0)	25.4 (1.0)	25.4 (1.0)	25.4 (1.0)
B4	12.2 E9 (0.48)	12.8 (0.506)	12.2 E9 (0.48)	12.8 (0.506)
B5	-	-	8.2 (0.323)	8.2 (0.323)

Front Adapter Dimensions - mm (in.)						
	Adapter Type					
	M	E	N	F	P	G
C1	see table on page 21					
C2	10.9 (0.429)	10.9 (0.429)	12.9 (0.508)	12.9 (0.508)	30 (1.18)	30 (1.18)
C3	see table on page 21					
C4	12.2 E9 (0.48)	12.8 (0.506)	12.2 E9 (0.48)	12.8 (0.506)	M12 × 1.75	1/2-20 NF-2B
C5	-	-	8.2 (0.323)	8.2 (0.323)	19 (0.748)	19 (0.748)
C6	-	-	-	-	35 (1.38)	35 (1.38)

## Dimensions

Maximum Dynamic Load and Stroke Relationships							
Maximum Dynamic Load (Fx) - kN (lbs.)	Total Length (Ltot), Retracted Length (A) and Adapter Dimensions [mm]	Ordering Stroke (S) [mm]					
		100 – 500	550 – 600	650 – 700	750 – 900	950 – 1000	
1.7 (382)	Ltot	A + B1 + C2					
	A	S + 150.9 + B2 + C1					
	C1	Type M, E	17.5				
		Type N, F	26.5				
		Type P, G	23.9				
C3	30.16						
2.6 (585)	Ltot	A + B1 + C2			A + B1 + C2		
	A	S + 150.9 + B2 + C1			S + 156.8 + B2 + C1		
	C1	Type M, E	17.5			24.0	
		Type N, F	26.5			27.0	
		Type P, G	23.9			24.9	
C3	30.16			34.93			
4.5 (2012)	Ltot	A + B1 + C2			A + B1 + C2		
	A	S + 150.9 + B2 + C1			S + 156.8 + B2 + C1		
	C1	Type M, E	17.5			24.0	
		Type N, F	26.5			27.0	
		Type P, G	23.9			24.9	
C3	30.16			34.93			
6.8 (1529)	Ltot	A + B1 + C2			A + B1 + C2		
	A	S + 150.9 + B2 + C1			S + 156.8 + B2 + C1		
	C1	Type M, E	17.5			24.0	
		Type N, F	26.5			27.0	
		Type P, G	23.9			24.9	
C3	30.16			34.93			
10 (2248)	Ltot	A + B1 + C2	A + B1 + C2				
	A	S + 180.9 + B2 + C1	S + 182 + B2 + C1				
	C1	Type M, E	17.5	24.0			
		Type N, F	26.5	27.0			
		Type P, G	23.9	24.9			
C3	30.16	34.93					

## Control Options

Electrak® HD electric linear actuators feature the Electrak Modular Control System, and each unit is shipped with the Electronic Monitoring Package. A generous offering of optional control and feedback features can be configured to fit most applications – all within the same design envelope. Details for each control option and its wiring are described on the following pages. Please contact customer support for more information at [www.thomsonlinear.com/cs](http://www.thomsonlinear.com/cs).

Control Option Type EXX		
Actuator supply voltage	[Vdc]	
HD12		9 - 16
HD24		18 - 32
Actuator current draw	[A]	see page 17

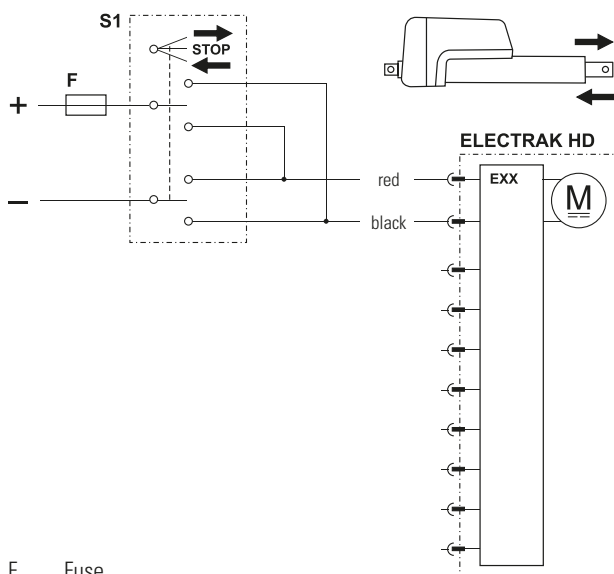

F Fuse  
S1 Double pole double throw switch

Control option EXX contains all of the basic Electrak Monitoring Package features described on page 7, guaranteeing safe operation of the actuator and equipment. With control option EXX, the polarity of the motor voltage is switched by a customer-supplied switch (switch, relay, etc.) to make the actuator extend or retract. The switch, power supply, wiring and all other components must be able to handle the motor current for the actuator model and load being used, as well as the inrush current (up to three times the max. continuous current for the max. load being used for up to 150 milliseconds).

Control Option Type ELX		
Actuator supply voltage	[Vdc]	
HD12		9 - 16
HD24		18 - 32
Actuator current draw	[A]	see page 17
Output contact type		potential free
Limit switch max. switch voltage	[Vdc]	140
Limit switch max. switch current	[mA]	350
Limit switch max. switch power	[W]	5

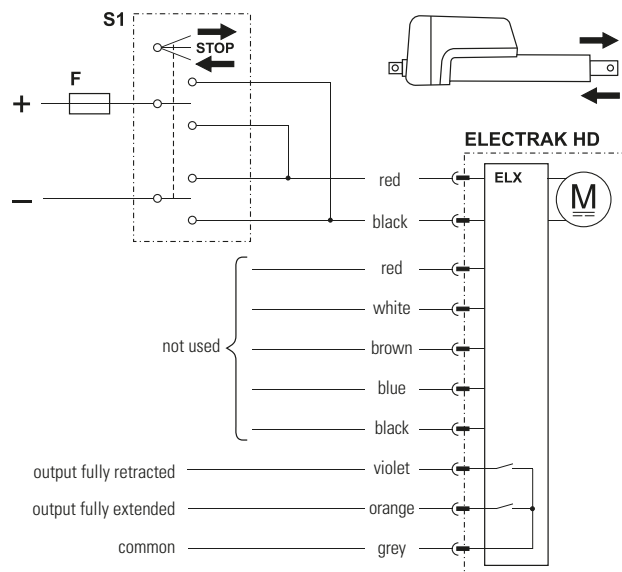

F Fuse  
S1 Double pole double throw switch

Control option ELX works as option EXX but also has two outputs that indicate when the extension tube is in its fully extended or retracted position.

# Control Options

Control Option Type EXP		
Actuator supply voltage	[Vdc]	
HD12		9 - 16
HD24		18 - 32
Actuator current draw	[A]	see page 17
Potentiometer type		wirewound
Potentiometer max. input voltage	[Vdc]	32
Potentiometer max. power	[W]	1
Potentiometer linearity	[%]	± 0.25
Potentiometer output resolution	[ohm/mm]	
50 - 100 mm stroke		65.62
150 - 250 mm stroke		32.81
300 - 500 mm stroke		19.69
550 - 1000 mm stroke		9.84

Control Option Type EXD		
Actuator supply voltage	[Vdc]	
HD12		9 - 16
HD24		18 - 32
Actuator current draw	[A]	see page 17
Encoder type		hall effect
Encoder input voltage	[Vdc]	4 - 24
Encoder output voltage levels	[Vdc]	
low (logical zero), typical / max.		0.1 / 0.25
Encoder resolution	[mm/pulse]	
HDxx-B026		0.154
HDxx-B045		0.092
HDxx-B068		0.068
HDxx-B100		0.040

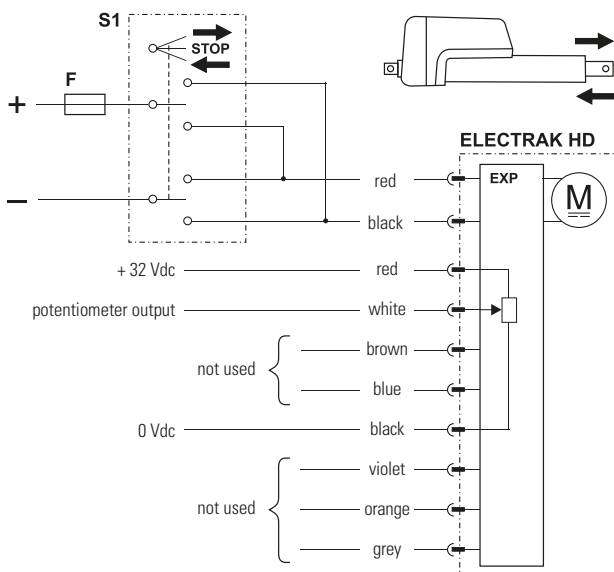

F Fuse  
S1 Double pole double throw switch

Control option EXP works as option EXX but also has an analog (potentiometer) output that will provide feedback on the extension tube position.

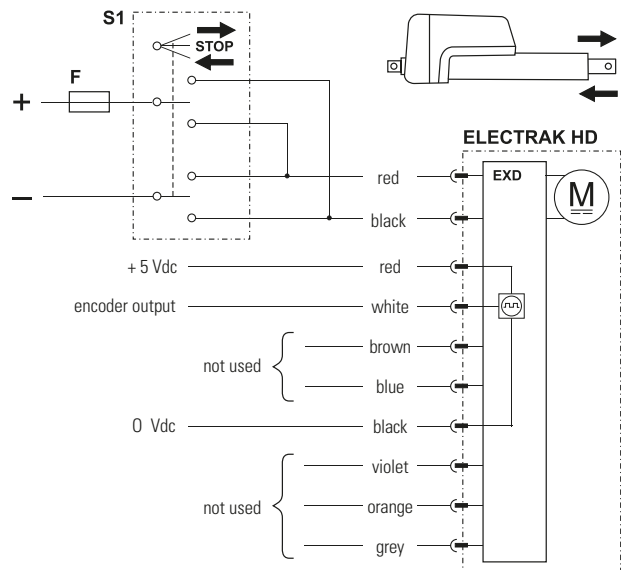

F Fuse  
S1 Double pole double throw switch

Control option EXD works as option EXX but also has a single-channel encoder output that will provide feedback on the extension tube position.

# Control Options

Control Option Type ELP		
Actuator supply voltage	[Vdc]	
HD12		9 - 16
HD24		18 - 32
Actuator current draw	[A]	see page 17
Output contact type		potential free
Max. output voltage	[Vdc]	140
Max. output current	[mA]	350
Max. output power	[W]	5
Potentiometer type		wirewound
Potentiometer max. input voltage	[Vdc]	32
Potentiometer max. power	[W]	1
Potentiometer linearity	[%]	± 0.25
Potentiometer output resolution	[ohm/mm]	
50 - 100 mm stroke		65.62
150 - 250 mm stroke		32.81
300 - 500 mm stroke		19.69
550 - 1000 mm stroke		9.84

Control Option Type ELD		
Actuator supply voltage	[Vdc]	
HD12		9 - 16
HD24		18 - 32
Actuator current draw	[A]	see page 17
Output contact type		potential free
Max. output voltage	[Vdc]	140
Max. output current	[mA]	350
Max. output power	[W]	5
Encoder type		hall effect
Encoder input voltage	[Vdc]	5
Encoder output voltage levels	[Vdc]	
low (logical zero), typical / max.		0.1 / 0.25
Encoder resolution	[mm/pulse]	
HDxx-B026		0.154
HDxx-B045		0.092
HDxx-B068		0.068
HDxx-B100		0.040

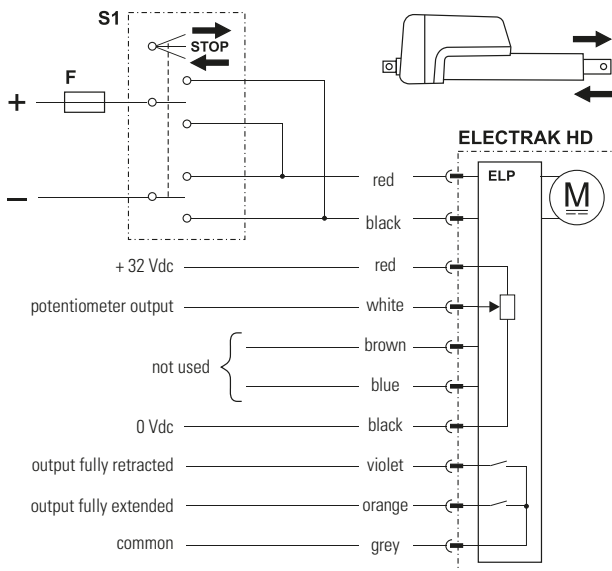

F Fuse  
S1 Double pole double throw switch

Control option ELP works as option EXP but also has two outputs that indicate when the extension tube is in its fully extended or retracted position.

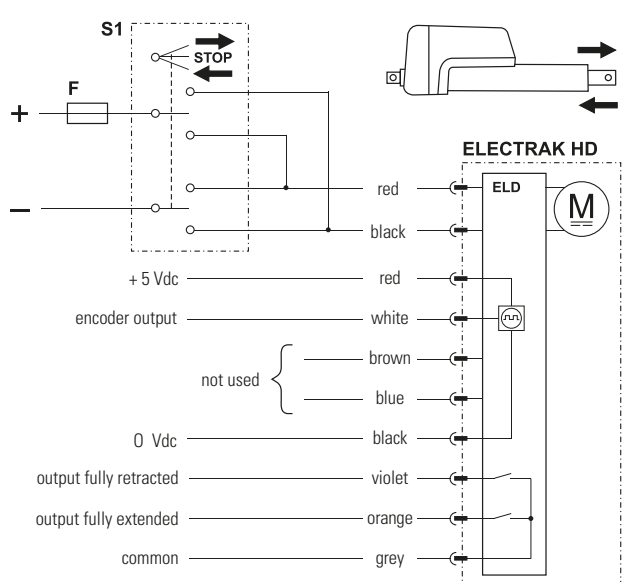

F Fuse  
S1 Double pole double throw switch

Control option ELD works as option EXD but also has two outputs that indicate when the extension tube is in its fully extended or retracted position.



## Control Options

### Control Option Type LXX

Actuator supply voltage	[Vdc]	
HD12		9 - 16
HD24		18 - 32
Actuator current draw	[A]	see page 17
Extend / retract input voltage	[Vdc]	9 - 32
Extend / retract input current	[mA]	6 - 22

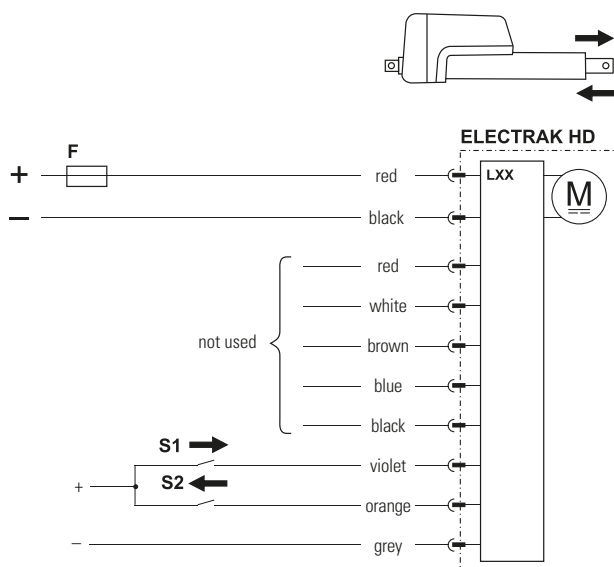

- F Fuse  
S1 Extend switch  
S2 Retract switch

Control option LXX has all the basic Electrak Monitoring Package features included in control option EXX, but the polarity of the motor voltage is switched by the onboard electronics instead. The customer-supplied switches used to command the actuator to extend or retract only need to handle low-level signals. However, the power supply and wiring that supply the actuator must be able to handle the motor current for the actuator model and load being used, as well as the inrush current (up to one and a half times the max. continuous current for the max. load being used for up to 150 milliseconds).

### Control Option Type LLX

Actuator supply voltage	[Vdc]	
HD12		9 - 16
HD24		18 - 32
Actuator current draw	[A]	see page 17
Output contact type		potential free
Max. switched output voltage	[Vdc]	140
Max. output current	[mA]	350
Max. output power	[W]	5
Extend / retract input voltage	[Vdc]	9 - 32
Extend / retract input current	[mA]	6 - 22

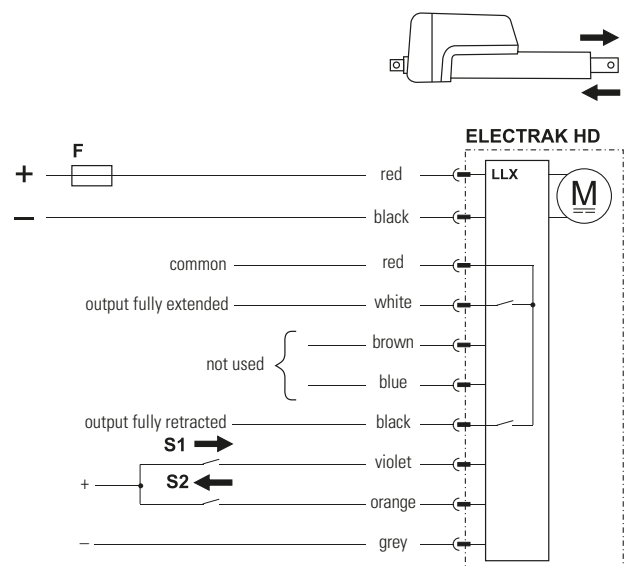

- F Fuse  
S1 Extend switch  
S2 Retract switch

Control option LLX works as option LXX but also has two outputs that indicate when the extension tube is in its fully extended or retracted position.

# Control Options

Control Option Type LXP		
Actuator supply voltage	[Vdc]	
HD12		9 - 16
HD24		18 - 32
Actuator current draw	[A]	see page 17
Potentiometer type		wirewound
Potentiometer max. input voltage	[Vdc]	32
Potentiometer max. power	[W]	1
Potentiometer linearity	[%]	± 0.25
Potentiometer output resolution	[ohm/mm]	
50 - 100 mm stroke		65.62
150 - 250 mm stroke		32.81
300 - 500 mm stroke		19.69
550 - 1000 mm stroke		9.84
Extend / retract input voltage	[Vdc]	9 - 32
Extend / retract input current	[mA]	6 - 22

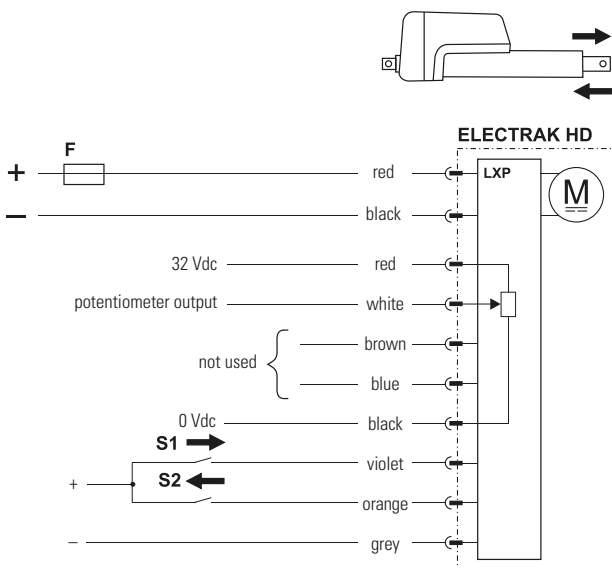

- F Fuse
- S1 Extend switch
- S2 Retract switch

Control option LXP works as option LXX but also has an analog (potentiometer) output that will provide feedback on the extension tube position.

Control Option Type CNO		
Actuator supply voltage	[Vdc]	
HD12		9 - 16
HD24		18 - 32
Actuator current draw	[A]	see page 17
Command data includes:		
• position		
• speed		
• current		
Feedback data includes:		
• position		
• speed		
• current		
• other diagnostic information		

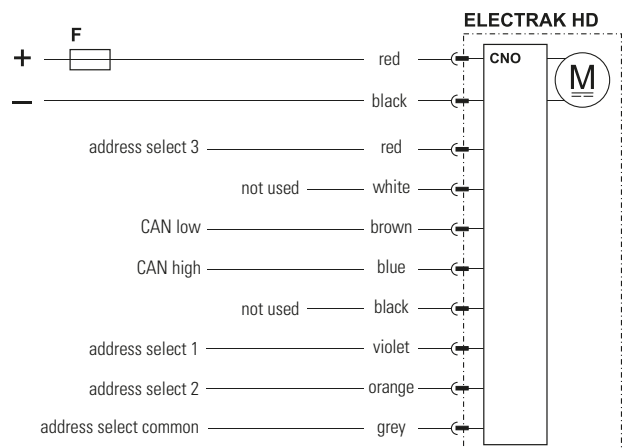
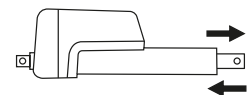

F Fuse

Control option CNO has a J1939 CAN bus control interface that controls and monitors the actuator. Extend and retract commands are sent via CAN messages on the CAN low and CAN high pins. Address select 1, 2 and 3 pins can be used as a BCD encoded adder to the default address. This can be used when multiple J1939 actuators are located on a single bus.

## Accessories

Limit Switches for Cover Tube Mounting		
Sensor type	solid state	reed switch
Contact type	normally open (N.O.)	
Output type	PNP	contact
Voltage [VDC/AC]	10 - 30 / -	5 - 120 / 5 - 120
Max. current [mA]	100	
Hysteresis [mm]	1.5	1.0
Operating temperature [°C]	- 25 to + 85	- 25 to + 85
Lead cross section [mm <sup>2</sup> ]	3 × 0.14	2 × 0.14
Length (L) [mm]	25.3	30.5
Protection class	IP69K	IP67
LED indicator	yes	
Connection	2 m cable with flying leads	
p/n	840-9131	840-9132

### Mounting positions

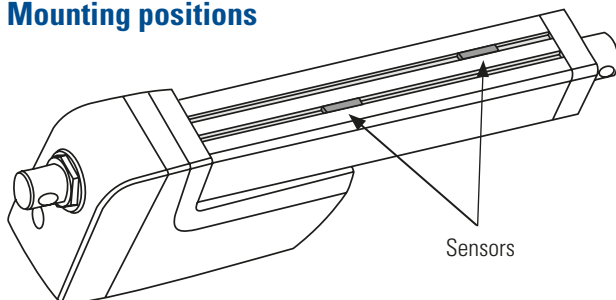

### Dimensions [mm]

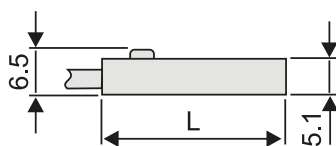

### Connection

Solid state

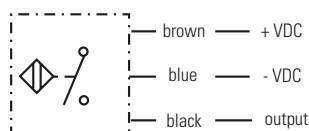

Reed switch

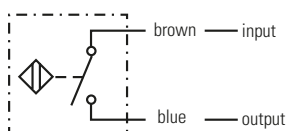

The limit switches are mounted in the cover tube slots and will be switched by a magnet mounted inside of the actuator on the extension tube.

### Rod End Front Adapter

Type	metric	inch
Material	CAD plated steel	
Dimensions		
A	12.0 ± 0.1 mm	0.5 in
B	14.3 ± 0.1 mm	0.625 in
C	M12	1/2-20 UNF
p/n	756-9021	756-9007

### Dimensions [mm (in)]

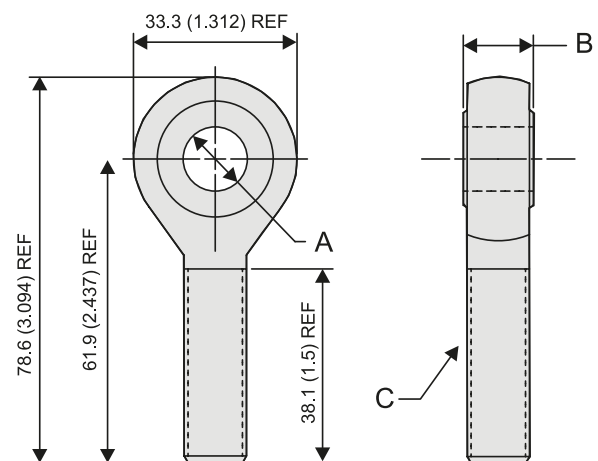

The rod end front adapter comes in one metric and one inch version. The metric adapter can be mounted to the front of the extension tube if the actuator is equipped with the metric female thread front adapter option (type P), while the inch adapter requires the inch female thread option (type G).

## Online Resources

Thomson offers a wide variety of online application, selection and training tools to help you in the selection process. An experienced team of application engineers is also available to help size and select an Electrak® HD model to best fit your application needs. To explore additional technical resources and options, contact Thomson customer support at [www.thomsonlinear.com/hd](http://www.thomsonlinear.com/hd).

### Electrak HD Microsite

Get additional information and learn more about the electromechanical advantage on our microsite. [www.thomsonlinear.com/hd](http://www.thomsonlinear.com/hd)

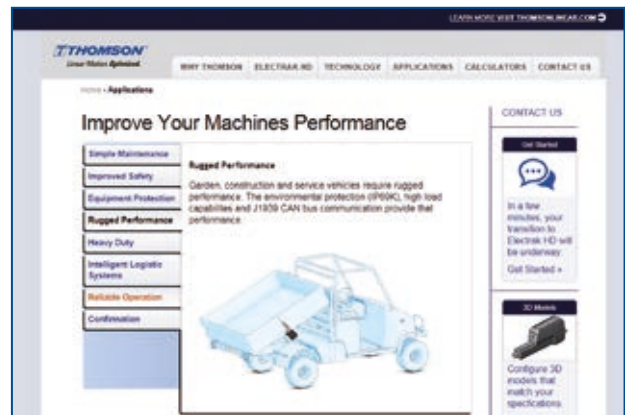

### Product Selector

The product selector will walk you through the selection process. [www.thomsonlinear.com/website/com/eng/products/actuators/linear\\_actuators\\_selector.php](http://www.thomsonlinear.com/website/com/eng/products/actuators/linear_actuators_selector.php)

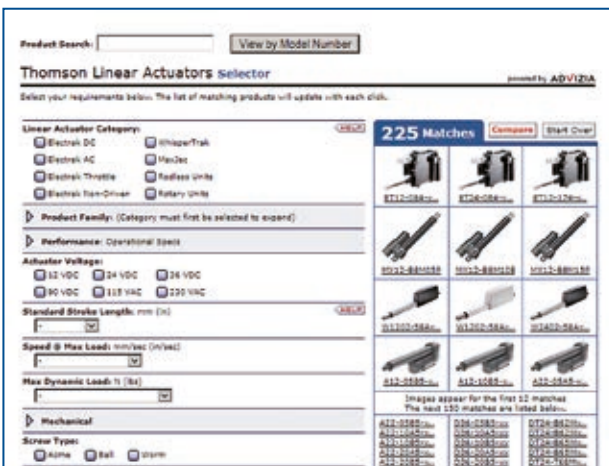

### Interactive 3D CAD Models

Download free interactive 3D CAD models in the most common CAD formats. [www.thomsonlinear.com/micro/electrakhd\\_eng/3d-model.html](http://www.thomsonlinear.com/micro/electrakhd_eng/3d-model.html)

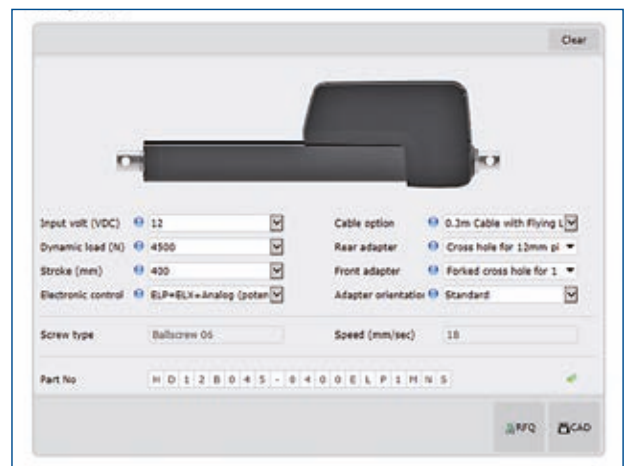

## Leverage Decades of Design and Application Expertise

Thomson is the market share leader for electric linear actuators in the most demanding applications, including construction and agriculture vehicles. We routinely collaborate with original equipment manufacturers globally to solve problems, boost efficiency and enhance the value passed on to their customers. Global contact information is available at [www.thomsonlinear.com/cs](http://www.thomsonlinear.com/cs).

From the pioneer in industrial actuators comes a legacy of technologies and application experience that can be harnessed to help with your next machine design, too.

Call today and let's talk about how our vast offering of standard, modified standard and custom solutions can deliver the optimal balance of performance, life and installed cost for you.



**1965**

Thomson **Performance Pak** electromechanical actuators are developed



**1967**

The first actuators for use in **garden tractors** and **farm equipment** are released



**1974**

**First line of actuators** with parallel motors and both acme and ball screw drive is released



**1982**

The **Electrak line of actuators** is released



**1987**

**Electrak 205** and the first line of **MCS controls** are released



**2007**

**Electrak Pro** series released



**2012**

**WhisperTrak** series released



**2013**

**Electrak Throttle** is released



**2013**

**Max Jac** heavy duty actuator released



**2016**

**Electrak HD** is released



## Frequently Asked Questions

Here are answers to common questions we receive. If you need more information, please contact customer support at [www.thomsonlinear.com/cs](http://www.thomsonlinear.com/cs).

### What is the typical life of an actuator?

Life is a function of load and stroke length. Please contact customer support for more information.

### What are the most common reasons for premature actuator failure?

Side load due to incorrect mounting, shock loading, exceeding the duty cycle and incorrect wiring are the most prominent causes for premature failure.

### What are IP ratings?

IP (International Protection Marking) ratings are commonly referenced standards that classify electrical equipment using standard tests to determine resistance to ingress of solid objects (first digit) and liquids (second digit). See the IP Ratings table below.

### Is Electrak HD suitable for tough environments such as washdown or extreme temperatures?

Yes. Electrak HD actuators are designed for washdown and have passed 200 hours of salt spray tests. They can operate in temperatures ranging from -40°C (-40°F) to +85°C (185°F).

### How is the duty cycle determined?

The duty cycle = on time / on time + off time. For example, if Electrak HD is powered for 15 seconds and then off for 45 seconds, the duty cycle for that minute would be 25%. All models are rated to 25% at full load, and an ambient temperature of 25°C (77°F). If load and/or ambient temperature are lower, then the duty cycle can exceed 25%. At higher temperatures, the duty cycle will be lower. Also see the duty cycle vs. load curve on page 19.

IP Rating		
Code	First Digit Definition	Second Digit Definition
0	No protection.	No protection.
1	Protected against solid objects over 50 mm.	Protected against vertically falling drops of water.
2	Protected against solid objects over 12.5 mm.	Protected against vertically falling drops of water, if the case is disposed up to 15° from vertical
3	Protected against solid objects over 2.5 mm.	Protected against vertically falling drops of water, if the case is disposed up to 60° from vertical
4	Protected against solid objects over 1 mm.	Protected against splash water from any direction.
5	Limited protection against dust ingress (no harmful deposits).	Protected against low-pressure water jets from any direction. Limited ingress permitted.
6	Totally dust protected.	Protected against high-pressure water jets from any direction. Limited ingress permitted.
7	–	Protected against short periods of immersion in water.
8	–	Protected against long, durable periods of immersion in water.
9K	–	Protected against close-range, high-pressure and high-temperature spray downs.

**Is Electrak HD maintenance free?**

Yes. Electrak HD never requires lubrication, maintenance or adjustment for wear.

**Is it possible for a load to back-drive the extension tube?**

No. The ball screw models incorporate a static load holding brake.

**What is the difference between a tension and a compression load?**

A tension load tries to stretch the actuator, while a compression load tries to compress it. With bi-directional loads, the end play of the actuator extension tube may need to be taken into consideration when using the actuator for positioning tasks.

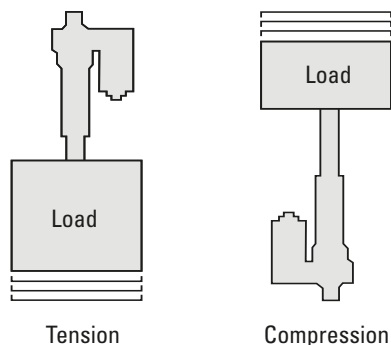
**Can Electrak HD be side loaded?**

No. A proper design of the application should eliminate any side loads.

**What is the range of input voltage an Electrak HD can operate with?**

A 12 Vdc version will accept 9 – 16 Vdc, while a 24 Vdc version will accept 18 – 32 Vdc. Outside of these limits, the Electronic Monitoring Package will prevent the actuator from operating.

**Can the speed of an Electrak HD be adjusted by changing the input voltage?**

No. As long as the input voltage is within the acceptable limits, the Electronic Monitoring Package will keep each Electrak HD at the correct speed for the load in question.

**What is the inrush current?**

The inrush current is a short current peak that appears at the start of an actuator as the motor tries to get the load moving. Typically, the inrush current will last between 75 to 150 milliseconds and can be up to three times higher (on a low-level switched actuator 1.5 times higher) than the current for the actuator and load. Batteries have no problem delivering the inrush current, but if using an AC-powered power supply, it is important to size it to handle the inrush current.

**What special mounting considerations does the Electrak HD require?**

There is no restraining torque that needs to be considered as Electrak HD is internally restrained. However, the actuator must be mounted so that there are no side loads acting on the extension tube. It is also important that the manual override input is accessible after the actuator is mounted and that connectors and cables are placed so that they are not damaged during operation.

**What is the maximum extension speed?**

The extension speed of an Electrak HD actuator is a function of the load. To determine the speed at a certain load, consult the load vs. speed charts on page 19. If a higher linear travel is required, a simple mechanical linkage can be employed.

## EUROPE

### United Kingdom

Thomson  
Office 9, The Barns  
Caddsdow Business Park  
Bideford  
Devon, EX39 3BT  
Phone: +44 (0) 1271 334 500  
E-mail: sales.uk@thomsonlinear.com

### Germany

Thomson  
Nürtinger Straße 70  
72649 Wolfschlügen  
Phone: +49 (0) 7022 504 0  
Fax: +49 (0) 7022 504 405  
E-mail: sales.germany@thomsonlinear.com

### France

Thomson  
Phone: +33 (0) 243 50 03 30  
Fax: +33 (0) 243 50 03 39  
E-mail: sales.france@thomsonlinear.com

### Italy

Thomson  
Largo Brughetti  
20030 Bovisio Masciago  
Phone: +39 0362 594260  
Fax: +39 0362 594263  
E-mail: info@thomsonlinear.it

### Spain

Thomson  
E-mail: sales.esm@thomsonlinear.com

### Sweden

Thomson  
Estridsväg 10  
29109 Kristianstad  
Phone: +46 (0) 44 24 67 00  
Fax: +46 (0) 44 24 40 85  
E-mail: sales.scandinavia@thomsonlinear.com

## SOUTH AMERICA

### Brazil

Thomson  
Av. Tamboré, 1077  
Barueri, SP – 06460-000  
Phone: +55 (11) 3616-0191  
Fax: +55 (11) 3611-1982  
E-mail: sales.brasil@thomsonlinear.com

## USA, CANADA and MEXICO

Thomson  
203A West Rock Road  
Radford, VA 24141, USA  
Phone: 1-540-633-3549  
Fax: 1-540-633-0294  
E-mail: thomson@thomsonlinear.com  
Literature: literature.thomsonlinear.com

## ASIA

### Asia Pacific

Thomson  
E-mail: sales.apac@thomsonlinear.com

### China

Thomson  
Rm 2205, Scitech Tower  
22 Jianguomen Wai Street  
Beijing 100004  
Phone: +86 400 6661 802  
Fax: +86 10 6515 0263  
E-mail: sales.china@thomsonlinear.com

### India

Thomson  
c/o Fluke Technologies Pvt. Ltd.  
#424, Deodhar Center,  
Marol Maroshi Road,  
Andheri – E, Mumbai – 400059 India  
Phone: +91 22 29207641  
E-mail: sales.india@thomsonlinear.com

### Japan

Thomson  
Minami-Kaneden 2-12-23, Suita  
Osaka 564-0044 Japan  
Phone: +81-6-6386-8001  
Fax: +81-6-6386-5022  
E-mail: csjapan@scgap.com

### Korea

Thomson  
F7 Ilsong Bldg, 157-37  
Samsung-dong, Kangnam-gu,  
Seoul, Korea (135-090)  
Phone: +82 2 6917 5049  
Fax: +82 2 528 1456  
E-mail: sales.korea@thomsonlinear.com

[www.thomsonlinear.com](http://www.thomsonlinear.com)

Electrak\_HD\_Actuator\_BRUK-0020-05B | 20170124SK

Specifications are subject to change without notice. It is the responsibility of the product user to determine the suitability of this product for a specific application. All trademarks property of their respective owners. © 2017 Thomson Industries, Inc.

 **THOMSON**<sup>®</sup>

*Linear Motion. Optimized.<sup>™</sup>*